

GasMultiBloc Combined regulator and safety shut-off valves Single-stage function

DUNGS®

MB-D(LE) 405 - 412 B01

7.01

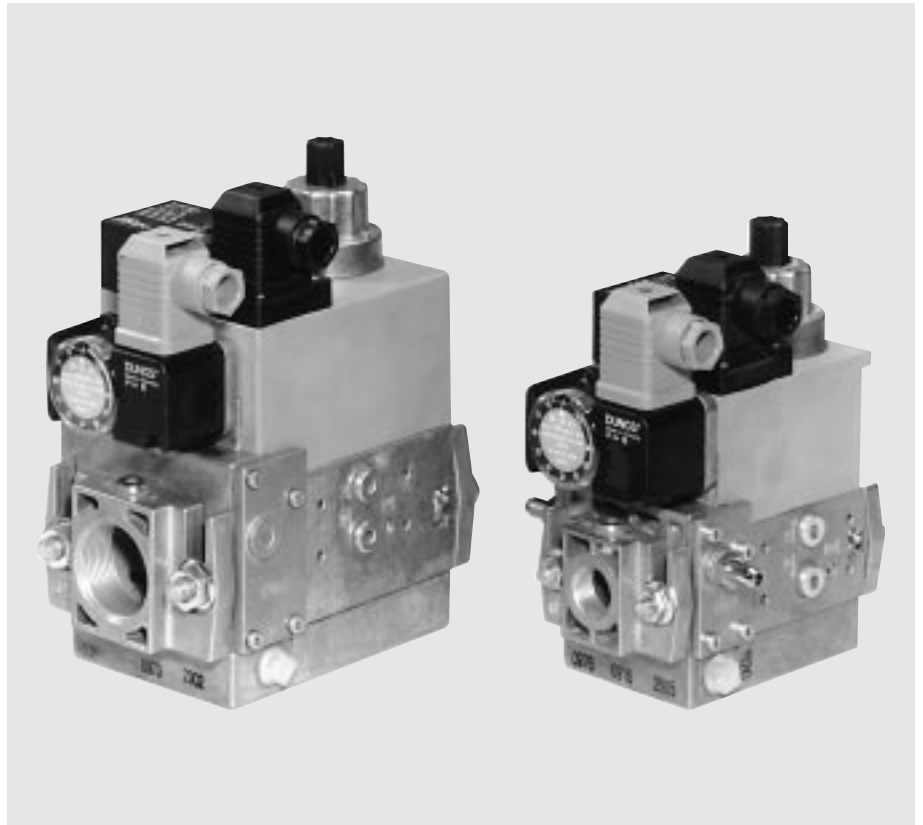

Technical description

The DUNGS GasMultiBloc integrates filter, regulator, valves and pressure switches in one compact fitting. Various designs are possible by the modular system:

- Dirt trap: microfilter
- One regulator and two valves: B01
- Two valves are fast opening
- One valve is fast opening and one valve is slow opening
- Solenoid valves up to 360 mbar as per DIN EN 161 Class A Group 2
- Sensitive setting of output pressure by proportional regulator as per DIN EN 88 Class A Group 2
- High flow rates with low pressure drop
- DC solenoid drive interference degree N
- Main volume restrictor at valve V2
- Hydraulic opening delay
- Flange connections with pipe threads as per ISO 7/1
- Simple mounting, compact, light-weight

The modular system permits individual solutions by using external ignition gas tap in connection with separately controlled

valves, by adding a valve proving system, mini/maxi pressure switches, pressure limiters, limit switch V2.

Application

The modular system permits individual solutions in gas safety and regulator engineering. Suitable for gases of families 1, 2, 3 and other neutral gaseous media.

Approvals

EU type test approval as per EU Gas Appliance Directive.

MB...405... B01	CE-0085 AP 0802
MB...407... B01	CE-0085 AR 0803
MB...410... B01	CE-0085 AR 0804
MB...412... B01	CE-0085 AR 0805

Approvals in other important gas-consuming countries.

Functional description of gas flow

When the valves V1 and V2 are closed, chamber A is under inlet pressure.

A hole D in the filter housing connects min. pressure switch with chamber A. If the inlet pressure applied to the pressure switch exceeds the incoming reference value, it switches through to the automatic burner control.

After release by the automatic burner control, valves V1 and V2 open. The gas flow through chambers A, B and C of the GasMultiBloc.

Operating method of valve-regulator combination on valve V1

A regulator, compensating for residual pressure is integrated in valve V1 (pressure regulating part). Armature 7 is not connected to valve plate unit 3. When it opens, armature 8 pretensions compression spring (V1) 5 and releases the valve plate unit.

When the valve closes, the armature acts directly on the valve plate unit.

The output pressure upstream of valve V2 is defined by pretensioning regulator spring 8 (tension spring) via setting screw 17.

The output pressure acts via opening E on the working diaphragm 21 of the regulator part. In regulated state, setting spring inlet pressure and pressure of working diaphragm are in force equilibrium.

The compensating diaphragm ensures the fast closing function of valve V1 and a high regulating quality.

Operating method of valve V2

Armature 14 of valve V2 is connected to valve plate unit 12. When it opens, armature 14 pretensions compression spring 13. The max. valve opening can be set by limiting the armature stroke by means of the main volume restrictor 18.

Min. opening (residual stroke) of valve (0.5 to 1.0 mm)

Main volume restrictor 18 is set by rotating the adjusting plate or the hydraulic brake. The fast and/or slow opening characteristic is influenced by setting fast stroke 19 at the hydraulic brake under the cover.

Closing function

When the supply voltage to the solenoid coils of valves V1 and V2 is interrupted, they are closed within < 1 s by the compression springs.

Sectional drawing of MB-DLE...

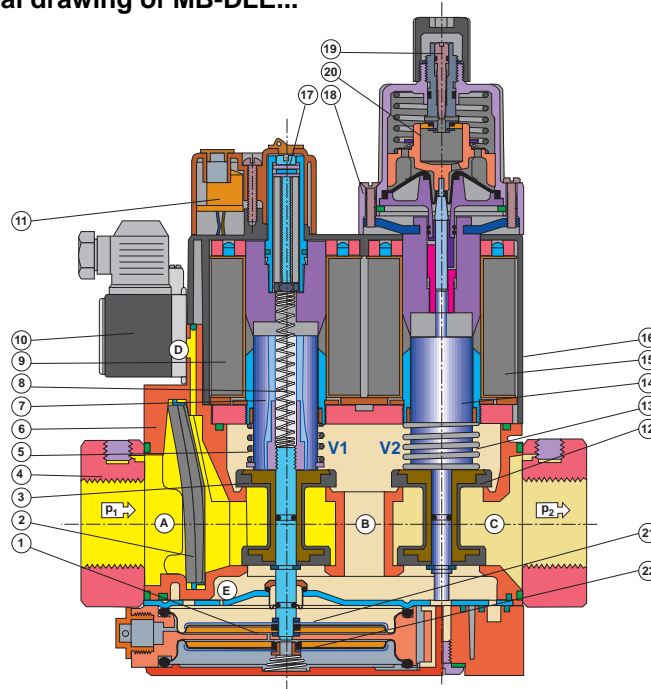

1	Pressure regulator	9	Solenoid V1	17	Setting:
2	Microfilter	10	Gas pressure switch	18	- Gas pressure p_a
3	Valve V1	11	Electrical connection	19	- Main volume
4	Connection flange	12	Valve V2	20	- Fast stroke
5	Closing spring V1	13	Closing spring V2	21	Working diaphragm
6	Housing	14	Armature V2	22	Compensation diaphragm
7	Armature V1	15	Solenoid V2		
8	Regulating spring	16	Solenoid housing		

Pressure taps

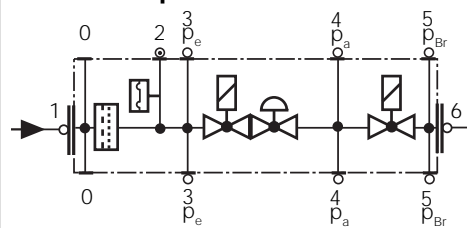

- 0 Filter cover
- 1,3,4,6 G 1/8 screw plug
- 2 Test nipple
- 5 M4 screwed sealing plug

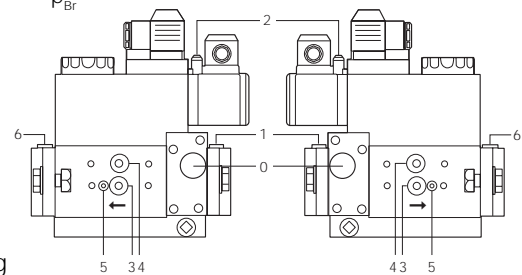

Electrical connection

IEC 730-1 (VDE 0631 T1)

S 20/S 50

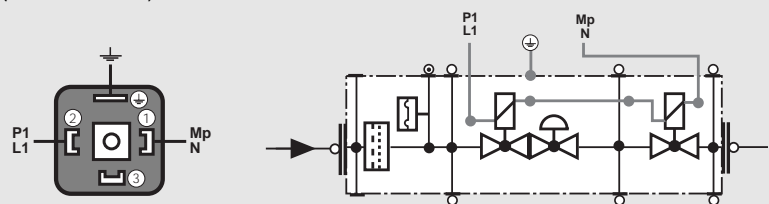

S 22/S 52

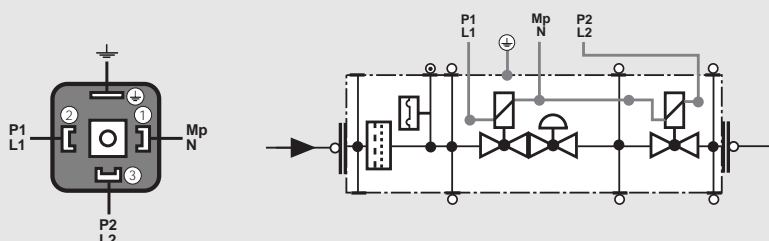

Specifications

Nominal diameters Flange with pipe threads as per ISO 7/1 (DIN 2999)	MB-...405/407 B01 Rp 1/2, 3/4 and their combinations	MB-...410/412 B01 Rp 3/4, 1, 1 1/4 and their combinations																				
Max. operating pressure	360 mbar (36 kPa)																					
Output pressure ranges	MB-... S20/S22 p_a: 4 mbar to 20 mbar MB-... S50/S52 p_a: 4 mbar to 50 mbar																					
Pressure stage	PN 1																					
Media	Gases of families 1, 2, 3 and other neutral gaseous media																					
Ambient temperature	-15°C to +70°C (Do not operate MB-D below 0°C in liquid gas systems. Only suitable for gaseous liquid gas, liquid hydrocarbons destroy sealing materials.)																					
Dirt trap	Sieve with 0.8 mm mesh width, filter made of random laid nonwoven fabric, microfilter, two-layer, changing the filter is possible without removing the valve.																					
Pressure switches	Types GW A5, GW A2, NB A2, ÜB A2 mountable as per DIN EN 1854. For further information, refer to Datasheet GW A2 No. 215 183 and Datasheet GW A5 No. 225 901.																					
Pressure regulator	Pressure regulator compensated for residual pressure, leakproof seal when switched off by means of valve V1 as per DIN EN 88 Class A. Setpoint spring permanently installed (no spring exchange possible). A vent line above roof is not required. Internal pulse tap provided.																					
Solenoid valve V1	Valve as per DIN EN 161 Class A Group 2, fast closing, fast opening																					
Solenoid valve V2	Valve as per DIN EN 161 Class A Group 2																					
	<table border="1"> <thead> <tr> <th></th> <th colspan="2">Valve V2 design</th> <th>Main volume restrictor</th> </tr> </thead> <tbody> <tr> <td>MB</td> <td>fast closing</td> <td>fast opening</td> <td>without</td> </tr> <tr> <td>MB-D</td> <td>fast closing</td> <td>fast opening</td> <td>with</td> </tr> <tr> <td>MB-DLE</td> <td>fast closing</td> <td>slow opening</td> <td>with</td> </tr> <tr> <td>MB-LE</td> <td>fast closing</td> <td>slow opening</td> <td>without</td> </tr> </tbody> </table>			Valve V2 design		Main volume restrictor	MB	fast closing	fast opening	without	MB-D	fast closing	fast opening	with	MB-DLE	fast closing	slow opening	with	MB-LE	fast closing	slow opening	without
	Valve V2 design		Main volume restrictor																			
MB	fast closing	fast opening	without																			
MB-D	fast closing	fast opening	with																			
MB-DLE	fast closing	slow opening	with																			
MB-LE	fast closing	slow opening	without																			
Measuring/ignition gas connection	For G 1/8 as per DIN ISO 228, refer to Pressure taps on page 2																					
Burner pressure monitor p _{Br}	Connection downstream of valve V2, pressure switch A2 mountable on adapter laterally																					
Voltage / frequency	50-60 Hz 220-230 V AC - 15% + 10% Other preferred voltages: 240 VAC, 110-120 VAC, 48 VDC, 24-28 VDC																					
Electrical connection	Plug connection as per DIN 43 650, IEC 335, IEC 730 (VDE 0700, VDE 0722) for valves and pressure switches																					
Rating/power consumption Switch-on duration Degree of protection Radio interference	Refer to Dimensions on page 5 100% IP 54 as per IEC 529 (EN 60529) Interference degree N																					
Materials of gas-conveying parts	Housing Diaphragms, seals Solenoid drive	aluminium die casting NBR basis, Silopren (silicone rubber) steel, brass, aluminium																				
Installation position	Solenoid vertically upright or lying horizontally as well as its intermediate positions																					
Closed position signal contact	Closed position signal contact, type K01/1 (DIN-tested), mountable on V2																					

Equipment variants GasMultiBloc...B01 Single-stage function	405 B01	407 B01	410 B01	412 B01	
MB	•	•	•	•	
MB-D	•	•	•	•	
MB-DLE	•	•	•	•	
MB-LE	•	•	•	•	
Microfilter with sieve	•	•	•	•	
Gas pressure switch downstream of filter	•	•	•	•	
downstream of valve V2 on adapter laterally	•	•	•	•	
downstream of valve V2 on flange with adapter	•	•	•	•	
Pressure regulator	•	•	•	•	
Valve V1, double seat	•	•	•	•	
Valve V2, single seat	•	–	•	–	
Valve V2, double seat	–	•	–	•	
Valves controlled together	•	•	•	•	S 20, S 50
Valves controlled separately	•	•	•	•	S 22, S 52
Flange Rp 1/2	•	•	–	–	• = possible (•) = on request - = not possible
Rp 3/4	•	•	•	•	
Rp 1	–	–	•	•	
Rp 1 1/4	–	–	•	•	

MB-...B01 version

- V1 = Valve 1
- V2 = Valve 2
- 3 = Dirt trap
- 4 = Pressure switch
- 5 = Regulator

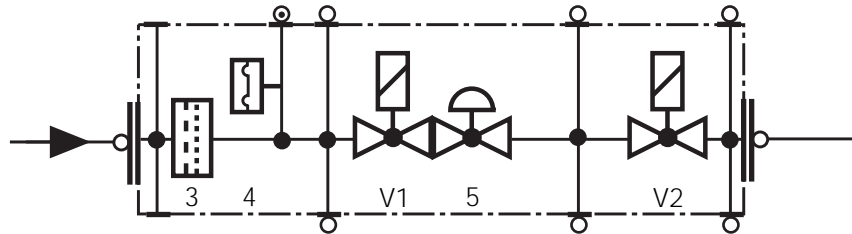

Mounting of VPS 504 valve proving system possible
Mounting of K01/1 closed position signal contact possible

Type key of MultiBloc

MB- XX XXX XX BOX SXX

Control of V1 and V2

0 = common
2 = separated

Outlet pressure Inlet pressure
2 = 4 - 20 mbar up to 360 mbar
5 = 4 - 50 mbar up to 360 mbar

S = Series (type-independent)

Gas train schematic diagram

1 = two A valves for main gas + regulator
2 = two A valves for main gas
7 = two A valves for main gas, one A valve together with V1 as internal bypass around V2 + regulator

Design type (generation) B

Construction size, nominal diameter

403 = DN 10, V2 = Single-seat valve
405 = DN 15, V2 = Single-seat valve
407 = DN 20, V2 = Double-seat valve
410 = DN 25, V2 = Single-seat valve
412 = DN 32, V2 = Double-seat valve
415 = DN 40, V2 = Double-seat valve
420 = DN 50, V2 = Double-seat valve

Opening behaviour + main volume restrictor

without = (MB or MB-ZR)
-D = Main volume restrictor
-LE = adjustable opening behaviour
-DLE = D + LE combination

without = single stage
ZR = double-stage with partial volume setting first stage

MultiBloc

Dimensions [mm]

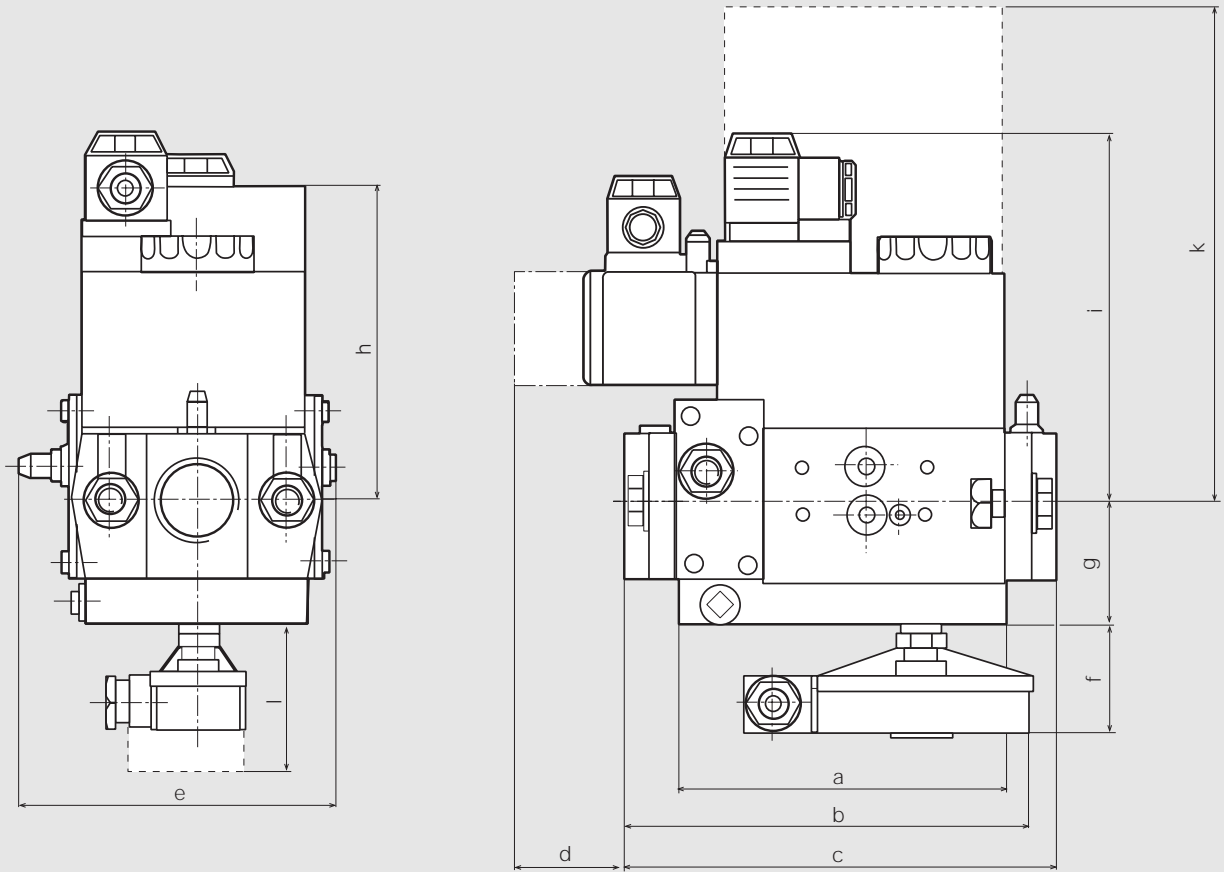

d = Space requirement for cover of pressure switch
 k = Space requirement for exchanging the solenoid
 l = Space requirement for K01/1 closed position signal contact

Type	Rp	Opening time	Dimensions [mm]											Weight [kg]	
			a	b	c	d	e	f	g	h	i	j	k		l
MB-D 405/407 B01	Rp 1/2	< 1 s	110	151	155	40	120	50	46	115	100	150	185	80	2.25/2.25
MB-DLE 405/407 B01	Rp 3/4	< 20 s	110	151	155	40	120	50	46	115	140	150	185	80	2.35/2.35
MB-D 410/412 B01	Rp 1	< 1 s	140	185	185	40	145	50	55	135	125	162	245	80	4.55/4.65
MB-DLE 410/412 B01	Rp 1 1/4	< 20 s	140	185	185	40	145	50	55	135	160	162	245	80	4.65/4.75

Rating / power consumption

[VA] ~(AC) 230 V AC; +20 °C:

MB 405/407 S 20	28
MB 405/407 S 50	36
MB 405/407 S 22	46
MB 405/407 S 52	46
MB 410/412 S 20	50
MB 410/412 S 50	50
MB 410/412 S 22	96
MB 410/412 S 52	96

GasMultiBloc
Combined regulator and
safety shut-off valves
Single-stage function

MB-D(LE) 405 - 412 B01

DUNGS®

Volumetric flow pressure loss characteristics in regulated state with microfilter

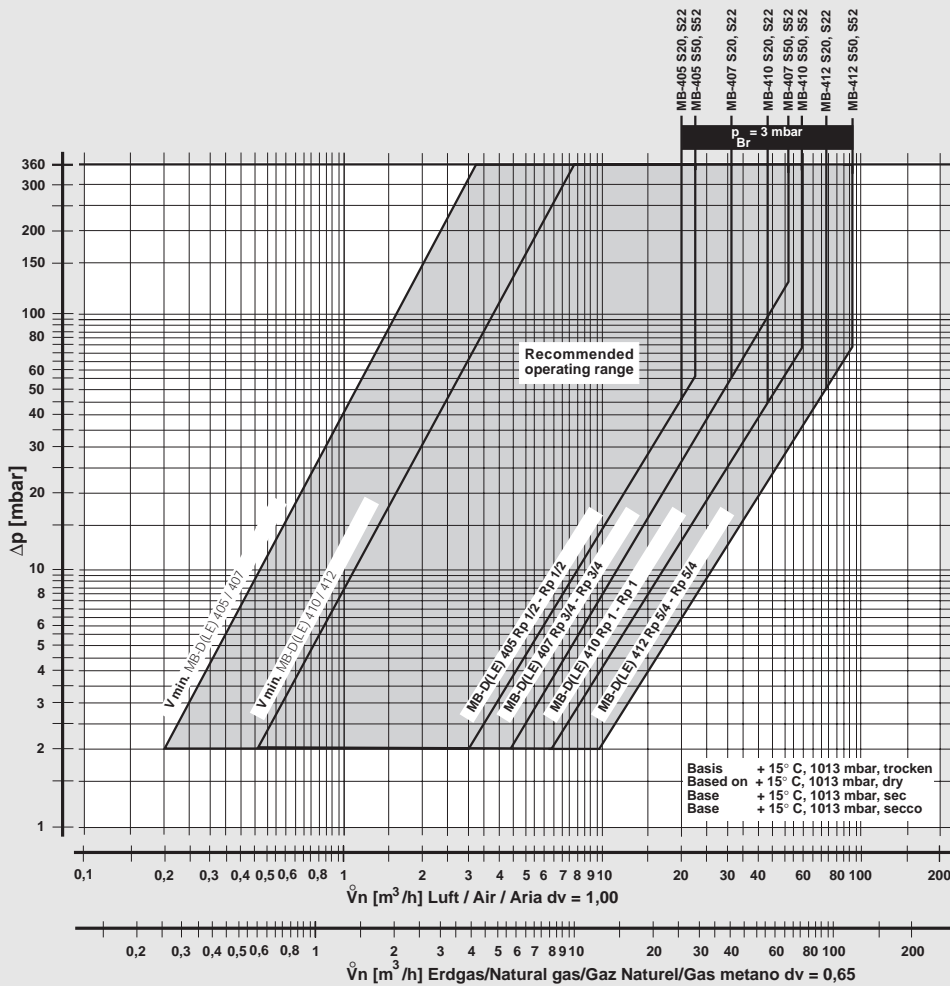

$$f = \sqrt{\frac{\text{Dichte Luft} \cdot \text{Spec. weight air} \cdot \text{poids spécifique de l'air} \cdot \text{peso específico aria}}{\text{Dichte des verwendeten Gases} \cdot \text{Spec. weight of gas used} \cdot \text{poids spécifique du gaz utilisé} \cdot \text{peso específico del gas utilizado}}}$$

Gas type	Spec. Wgt. [kg/m³]	dv	f
Nat. gas	0.81	0.65	1.24
City gas	0.58	0.47	1.46
LPG	2.08	1.67	0.77
Air	1.24	1.00	1.00

$$\dot{V}_{\text{verwendetes Gas/gas used/ gaz utilisé/gas utilizzato}} = \dot{V}_{\text{Luft/air/aria}} \times f$$

We reserve the right to make any changes in the interest of technical progress.



Head Offices and Factory
Karl Dungs GmbH & Co.
Siemensstraße 6-10
D-73660 Urbach
Telephone +49 (0)7181 804-0
Telefax +49 (0)7181 804-166

Postal address
Karl Dungs GmbH & Co.
Postfach 12 29
D-73602 Schorndorf
e-mail info@dungs.com
Internet www.dungs.com