

Installation & Maintenance Manual

MOL 795/1175 (B55-2/3 – B65-2/3)

Oil Burner

Contents

01. GENERAL	6
Description B55/B65/	6-7
Declaration of conformity	8
Manual	9
Safety directions	9
02. TECHNICAL DATA	10
Type designation B55-2H/B55-2/B55-2R/B55-3/B65-2H/B65-2/B65-2R/B65-3	10
Dimensions	10
Output range and nozzles recommended	10
Recommended nozzle and pressure	10
Working field	11
Nozzle table	12
03. INSTALLATION	13
Acceptance inspection	13
Preparations for installation	13
Distribution of oil	13
Electrical connections	13
Choice of nozzle	13
Setting of the brake plate and air flow	13
Burner installation	14
Hole pattern	14
Installing the burner	14
Oil lines	14
Electrical connections	14
04. BASIC SETTINGS	15
Typical basic settings for B65-2H/B65-2/B65-2R/B65-3R	15
Set values for nozzle assembly B55	16
Set values for nozzle assembly B65	16
Set values for air damper B55	16
Set values for air damper B65	16
Nozzle assembly regulation – fixed brake plate	17
Nozzle assembly regulation – adjustable brake plate	17
Hydraulic air adjustment	17
Damper motor 2-Stage	18
Damper motor 3-Stage	19
05. MAINTENANCE	20
Servicing the burner device	20
Adjusting the ignition electrodes and brake plate	20
Servicing the air damper	21
Replacing the damper motor	21
Replacing the oil pump B55/B65	21
06. INSTRUCTIONS PUMP TYPE RSA 95 & 125	22
Technical data	22
Components	22
Mounting/dismounting by-pass plug	22
Purging	22
Replacing the filter	22
Function Danfoss RSA 95 - 125	23
Suction line tables	24

09. ELECTRIC EQUIPMENT	25
Wiring diagram LOA44.../LMO24.255... (B55-2H/B65-2H)	25
Wiring diagram LOA44.../LMO24.255... (B55-2/B65-2/B55-2R/B65-2R)	26
List of components LOA44.../LMO24.255... (B55-2H/B65-2H/B55-2R/B65-2R)	27
Function LOA44.../LMO24.255...	27
Technical data LOA44.../LMO24.255...	27
Wiring diagram LAL 1... (B55-2/B55-2R/B65-2/B65-2R)	28
List of components LAL 1... (B55-2/B55-2R/B65-2/B65-2R)	29
Function LAL 1...	29
Wiring diagram LAL 1... (B55-3/B65-3)	30
Wiring diagram LAL 1... (B55-3/B65-3 with regulator RT 16)	31
List of components LAL 1... (B55-3/B65-3 och B55-3/B65-3)	32
Function LAL 1...	32
Control programme under fault conditions and lock-out indication LAL 1...	33
Technical data LAL 1...	33
Manual RT 16	34
Function RT 16	35
10. FAULT LOCATION	36
Burner fails to start	36
Burner fails to start after normal operation	36
Delayed ignition, burners starts violently	36
11. SPARE PART LIST	37-39

01. GENERAL

Description B55/B65

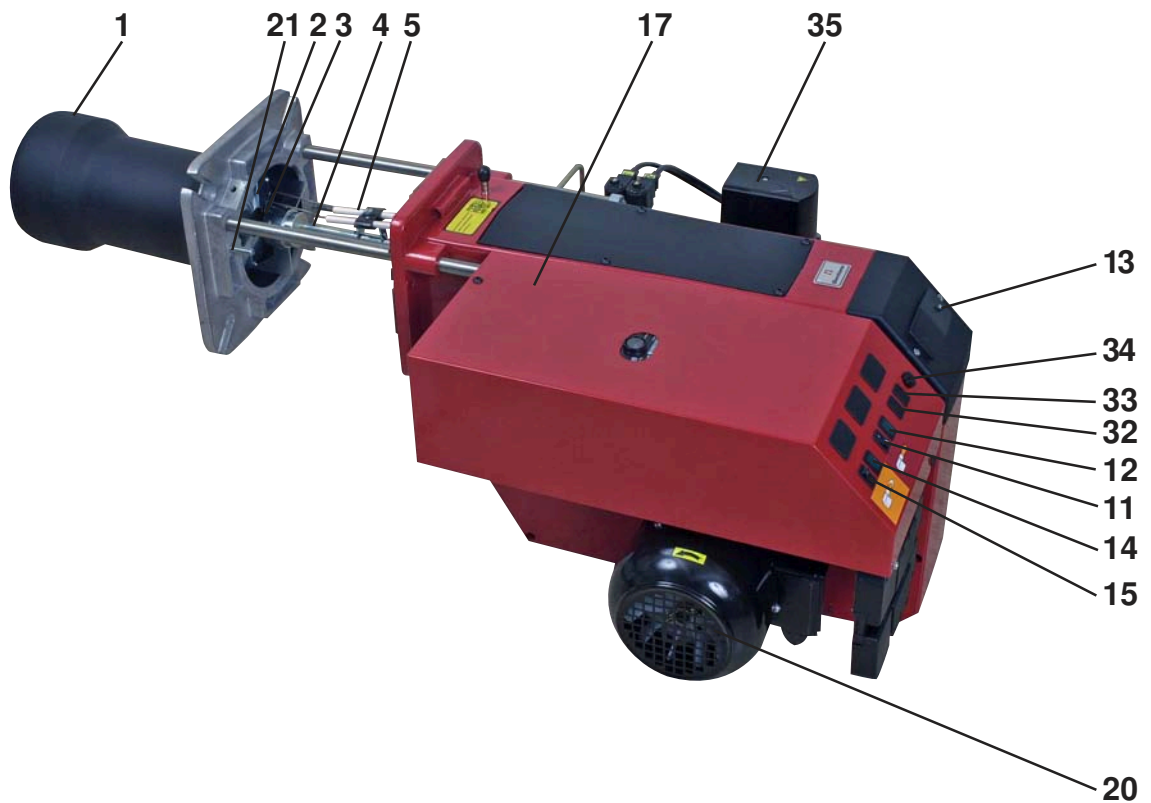

31a 27a 26a 27b 25a 22 23a



Components

- | | |
|-----------------------------|---------------------------------------|
| 1. Flame cone | 22. Solenoid valves |
| 2. Brake plate | 23a. Connecting pipe |
| 3. Nozzle | 25a. Solenoid valve bloc Stage 2 |
| 4. Nozzle assembly | 26a. Nozzle assembly adjustment fixed |
| 5. Ignition electrodes | 27a. Scale, air regulation |
| 11. Switch I-II | 27b. Scale, nozzle assembly |
| 12. Indicating lamp Stage 2 | 31a. Adjustment device, air damper |
| 13. Cover, inspection glass | 32. Switch II-III |
| 14. Indicating lamp Stage 1 | 33. Indicating lamp Stage 3 |
| 15. Switch 0-I | 34. Fuse |
| 17. Electric panel | 35. Damper motor |
| 20. Motor | |
| 21. Locking device, flange | |

01. GENERAL

Description B55/B65

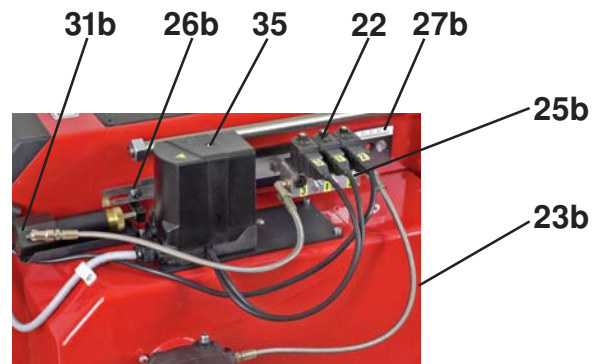
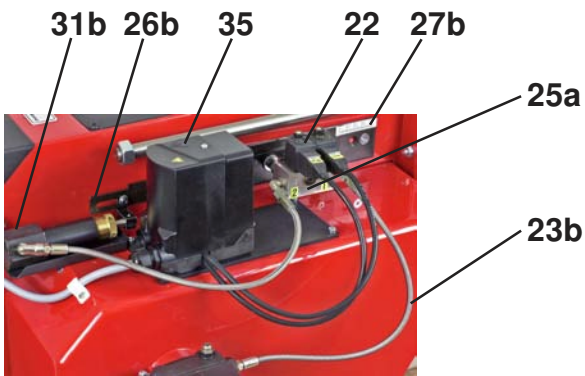
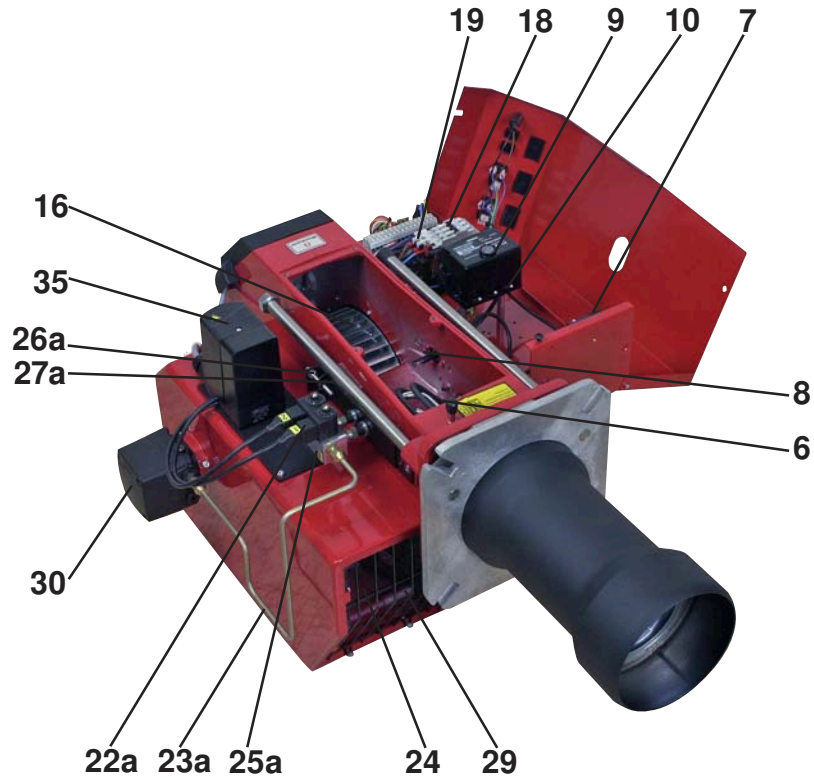

Components

- | | | | |
|------|-----------------------------|------|--------------------------------------|
| 6. | Ignition cables | 25a. | Solenoid valve bloc Stage 2 |
| 7. | Ignition transformer | 25b. | Solenoid valve bloc Stage 3 |
| 8. | Photocell | 26a. | Nozzle assembly adjustment fixed |
| 9. | Control box | 26b. | Nozzle assembly adjustment hydraulic |
| 10. | Front plate, relay base | 27b. | Scale, Nozzle assembly |
| 16. | Fan wheel | 29. | Air damper |
| 18. | Contacteur | 31b. | Adjustment device, Nozzle assembly |
| 19. | Thermal overload protection | 35. | Damper motor |
| 22. | Solenoid valve | | |
| 23b. | Hydraulic hose | | |
| 24. | Air intake | | |

01. GENERAL

Declaration of conformity

Manufacturer: Enertech AB, Bentone Division
Street address: Näsvägen
SE-341 34 Ljungby
Address: P.O. Box 309
SE-341 26 Ljungby
Sweden
Product: Oil burner
Type: B 1, B 2, B 9, B 10, B 11, B 20, B 30, B 40, B 45, B 50,
B 55, B 60, B 65, B 70, B 80, ST 97, ST 108, ST 120,
ST133, ST 146

Certifikat TÜV Süddeutschland
Certifikat Nr Burner
021198p15001 ST97, ST108, ST120, ST133, ST146
02119815002 B9, B10, B11
02119815003 B20, B30, B40, B45
02119815004 B50, B60, B70, B80

Enertech AB declares under sole responsibility that the above mentioned product is in conformity with the following standards or other normative documents.

Document: EN 267

and follows the provisions of applicable parts in the following EU Directives:

89/336/EEC Electromagnetic compatibility
73/23/EEC Low-voltage directive
89/392/EEC Machinery directive
92/42/EEC Efficiency directive

In that the burner conforms to the above mentioned standards it is awarded the CE mark.

Enertech AB, Bentone Division is quality certified according to SS-EN ISO 9001:2000

Ljungby, Sweden June 2004

Sven-Olov Lövgren



.....

01. GENERAL

Manual

- The contents of this manual are to be observed by all who work for any reason on the unit and its appertaining system parts.
- This manual is intended especially for authorised personnel.
- This manual is to be regarded as part of the burner and shall always be available near the place of installation.

Safety directions

The electrical installation shall be made according to valid regulations for heavy current and in a professional way, so that the risk of leaking oil, fire or personal injury is avoided.

Condensation in chimney

A modern burner works with less air surplus and often with a smaller nozzle than older models. This improves the efficiency but increases also the risk of condensation in the chimney. The risk is greater if the cross sectional area of the chimney flue is too big. Temperature of the flue gases should be higher than 60 °C measured 0.5 m from the top of the chimney.

Setting the burner

A flue-gas analysis and measuring of the temperature should be done to facilitate a correct setting. There is otherwise a risk of soot, poor efficiency or condensation in the chimney.

02. TECHNICAL DATA

Type designation B55-2H/B55-2/B55-2R/B55-3R/B65-2H/B65-2/B65-2R/B65-3R

Dimensions

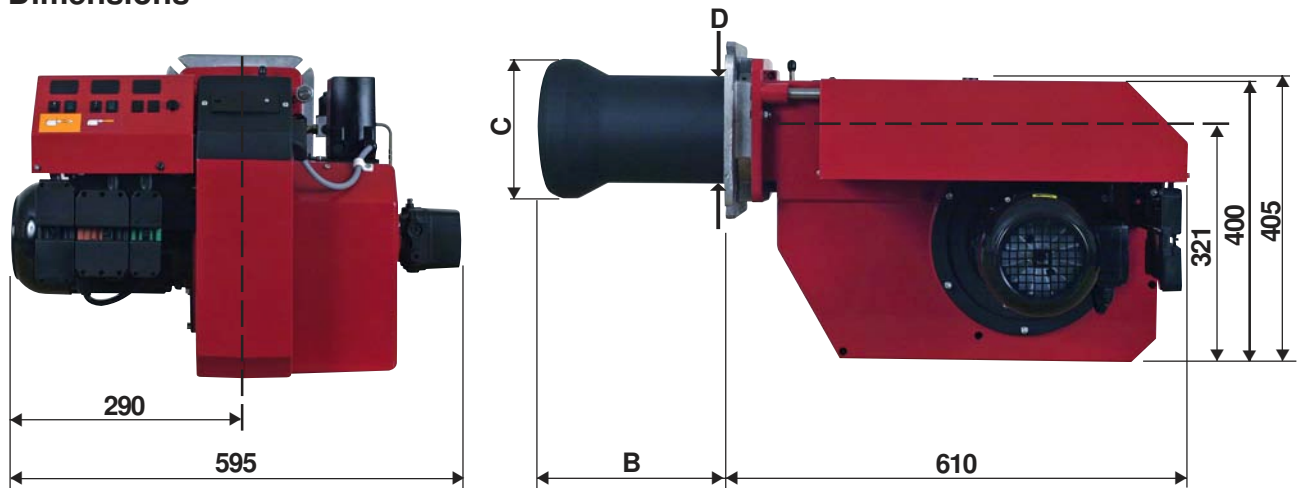

	Length of burner tube B55	Flange Measure B B55	Burner tube Measure C B55	Burner tube Measure D B55	Length of burner tube B65	Flange Measure B B65	Burner tube Measure C B65	Burner tube Measure D B65
Standard 1	303	273	160	155	288	258	210	155
Standard 2	403	373	160	155	388	358	210	155
Standard 3	503	473	160	155	488	458	210	155

Output range and nozzles recommended

	Oil capacity kg/h	Output kW	Output Mcal/h	Recommended nozzle Angle	Recommended Danfoss	Recommended Pump pressure
B55-2H, B55-2, B55-2R	14-67	166-795	143-685	45°-60°	S, B	14 bar
B55-3R	14-64	166-759	143-654	45°-60°	S, B	14 bar
B65-2H, B65-2, B65-2R	24-99	285-1174	246-1012	45°-60°	S, B	14 bar
B65-3R	24-99	285-1174	246-1012	45°-60°	S, B	14 bar

The net calorific value of 11,86 kWh/kg for light oil has been used.

Recommended nozzle and pressure

Because of the different boiler types, combustion chamber geometries and combustion chamber loads that exist, it is not possible to specify a given spray angle or spray pattern. It should be noted that the spray angle and spray pattern will vary depending on the pump pressure.

Nozzle

45°S Danfoss
45°B Danfoss
60°S Danfoss
60°B Danfoss

Pump pressure

14 bar (12 - 16 bar)
On burners equipped with hydraulic air control or optimization the oil pressure should not be less than 14 bar.

02. TECHNICAL DATA

Working field

B55-2

14-67 kg/h
166-795 kW

— B55-2R
— B55-2H/B55-2
- - - Measured (test)

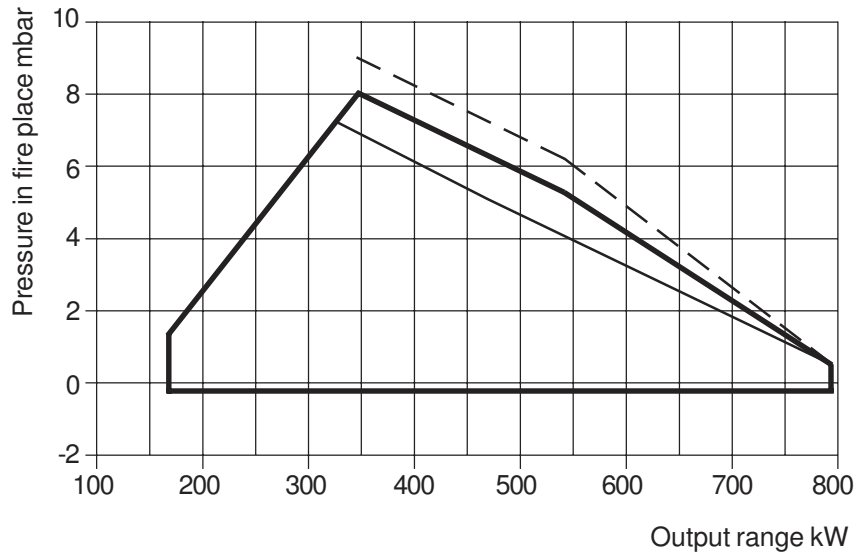

B55-3R

14-64 kg/h
166-759 kW

— B55-3R
- - - Measured (test)

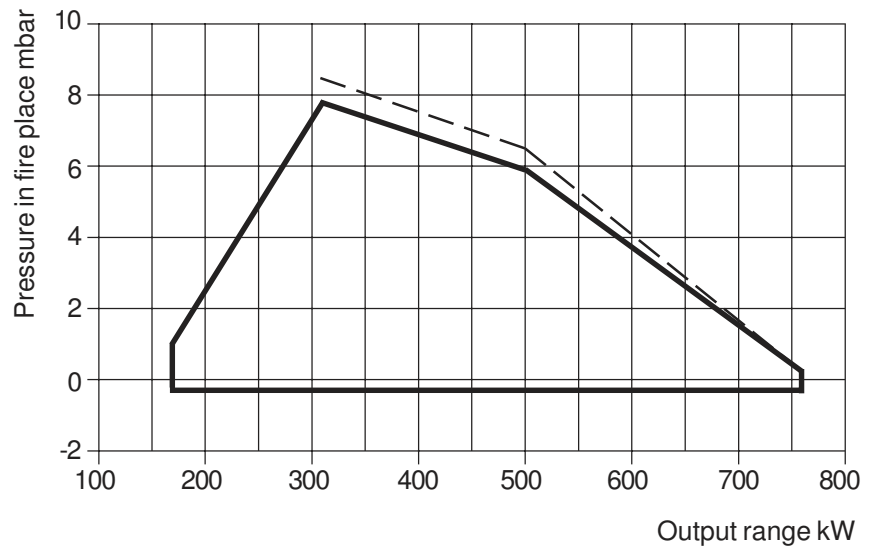

B65

24-99 kg/h
285-1174 kW

— B65
- - - Measured (test)

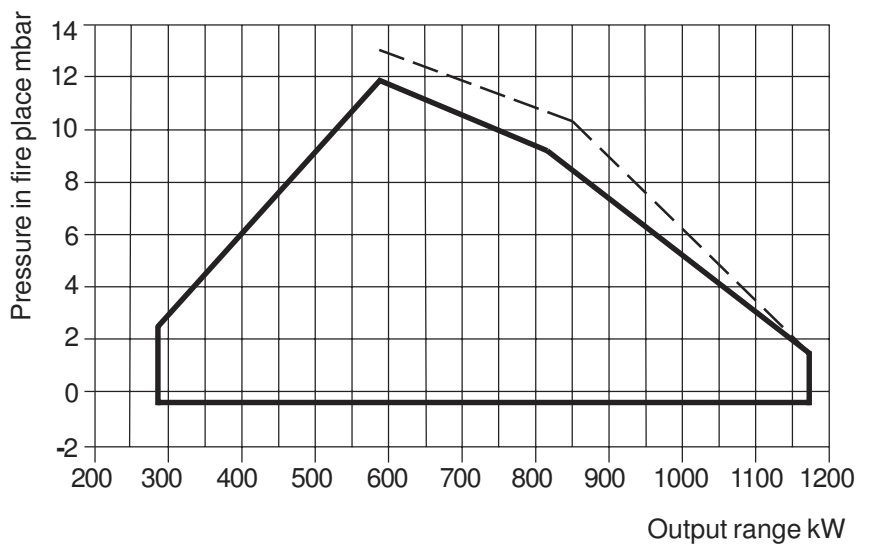

Unbroken line is the approved working field as per EN267.

02. TECHNICAL DATA

Nozzle table

Pump pressure bar

Gph	10			11			12			13		
	kg/h	kW	Mcal/h	kg/h	kW	Mcal/h	kg/h	kW	Mcal/h	kg/h	kW	Mcal/h
2,75	10,24	121	104	10,73	127	109	11,21	133	114	11,67	138	119
3,00	11,16	132	114	11,71	139	119	12,23	145	125	12,73	151	130
3,50	13,03	154	133	13,66	162	139	14,27	169	146	14,85	176	151
4,00	14,89	176	152	15,62	185	159	16,31	193	166	16,97	201	173
4,50	16,75	199	171	17,57	208	179	18,35	218	187	19,10	226	195
5,00	18,62	220	190	19,52	231	199	20,39	242	208	21,22	252	216
5,50	20,48	243	209	21,47	255	219	22,43	266	229	23,34	277	238
6,00	22,34	265	228	23,42	278	239	24,47	290	250	25,46	302	260
6,50	24,20	287	247	25,37	301	259	26,51	314	270	27,58	327	281
7,00	26,06	309	266	27,33	324	279	28,55	339	291	29,70	352	303
7,50	27,92	331	285	29,28	347	299	30,59	363	312	31,83	377	325
8,00	29,79	353	304	31,23	370	318	32,63	387	333	33,95	403	346
8,50	31,65	375	323	33,18	393	338	34,66	411	353	36,07	428	368
9,00	33,59	398	343	35,14	417	358	36,71	435	374	38,19	453	389
9,50	35,37	419	361	37,09	440	378	38,74	459	395	40,31	478	411
10,00	37,23	441	380	39,04	463	398	40,78	484	416	42,44	503	433
11,00	40,96	486	418	42,94	509	438	44,86	532	457	46,68	554	476
12,00	44,68	530	456	46,85	556	478	48,94	580	499	50,92	604	519
14,00	52,12	618	531	54,65	648	557	57,10	677	582	59,41	705	606
16,00	59,57	706	607	62,46	741	637	65,26	774	666	67,90	805	692
18,00	67,02	795	683	70,27	833	717	73,41	871	749	76,39	906	779
20,00	74,47	883	759	78,08	926	796	81,57	967	832	84,87	1007	865

Pump pressure bar

Gph	14			15			16			17		
	kg/h	kW	Mcal/h	kg/h	kW	Mcal/h	kg/h	kW	Mcal/h	kg/h	kW	Mcal/h
2,75	12,11	144	123	12,53	149	128	12,95	154	132	13,35	158	136
3,00	13,21	157	135	13,67	162	139	14,13	168	144	14,56	173	148
3,50	15,42	183	157	15,95	189	163	16,49	196	168	16,99	201	173
4,00	17,62	209	180	18,23	216	186	18,84	223	192	19,42	230	198
4,50	19,82	235	202	20,51	243	209	21,20	251	216	21,84	259	223
5,00	22,03	261	225	22,79	270	232	23,55	279	240	24,27	288	247
5,50	24,23	287	247	25,07	297	256	25,91	307	264	26,70	317	272
6,00	26,43	313	270	27,49	326	280	28,27	335	288	29,13	345	297
6,50	28,63	340	292	29,63	351	302	30,62	363	312	31,55	374	322
7,00	30,84	366	314	31,91	378	325	32,98	391	336	33,98	403	347
7,50	33,04	392	337	34,19	405	349	35,33	419	360	36,41	432	371
8,00	35,25	418	359	36,47	433	372	37,69	447	384	38,80	460	396
8,50	37,45	444	382	38,74	459	395	40,04	475	408	41,26	489	421
9,00	39,65	470	404	41,02	486	418	42,40	503	432	43,69	518	446
9,50	41,85	496	427	43,30	514	442	44,75	531	456	46,11	547	470
10,00	44,06	523	449	45,58	541	465	47,11	559	480	47,11	559	480
11,00	48,46	575	494	50,14	595	511	51,82	615	528	53,40	633	545
12,00	52,87	627	539	54,70	648	558	56,53	670	576	58,25	691	594
14,00	62,68	732	629	63,81	757	651	65,95	778	669	67,96	806	693
16,00	70,49	836	719	72,93	865	744	75,38	894	769	77,67	921	792
18,00	79,30	940	809	82,05	973	837	84,80	1006	865	87,38	1036	891
20,00	88,11	1045	899	91,17	1081	930	94,22	1117	961	97,09	1151	990

The table applies to oil with a viscosity of 4,4 mm²/s (cSt) with density 830 kg/m³.

03. INSTALLATION

Acceptance inspection

Ensure that everything is delivered and that there is no transport damage. If there is anything wrong with the delivery, please report it to the supplier. Any transport damage should be reported to the forwarding company.

Preparations for installation

Ensure that the size and capacity range of the burner are suitable for the boiler. Power data on the data plate refer to the minimum and maximum power of the burner.

Distribution of oil

To ensure satisfactory operation it is essential that the oil distribution system is correct.

Observe the following:

- See Pump instructions for choice of tube diameter, tube length and height difference.
- Fix the tubing with a minimum number of screw fittings.
- Fix the tubes so that the oil hoses are not subjected to tensile stress or sharp bending when swinging out the burner or removing it for service.
- Fit the oil filter 1½" so that the filter cartridge can easily be replaced.

Electrical connections

The main power switch must be turned off before beginning electrical installation. If the boiler has a 7-pin and a 4-pin Eurostecker connector these will often connect straight to the burner. If not, use the connectors supplied. A 5-pin connector supplies the burner motor with a separate 3-phase supply. See connection under the Electrical equipment heading.



If another electrical connection is used than the one recommended by Bentone, there might be a risk of material damage or personal injury.

Choice of nozzle

See under Technical Data: Recommended nozzle and table of nozzles.

Setting of the brake plate and air flow

Basic burner settings can be made before commissioning as shown in the diagram. See Basic settings. Note that these are just basic settings and must be correctly adjusted when the burner has been started. Flue gas analysis and soot measurement should be carried out at this time.

03. INSTALLATION

Burner installation

Hole pattern

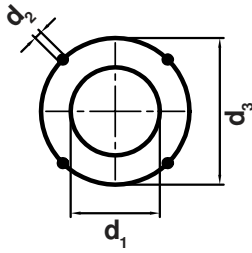

Check that the hole pattern on the boiler matches the pattern on the burner flange.

Flame head	d_1	d_2	d_3
B55	(160)* 165	M12	(226)* 254-295
B65	(160)* 210	M12	(226)* 254-295

* The hole pattern can be reduced if the burner pipe is fitted from the front and the heels in the flange are ground off.

Installing the burner

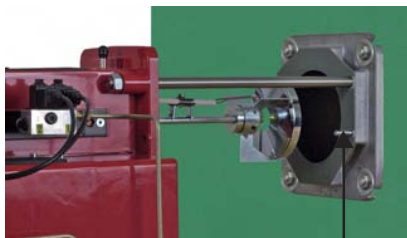
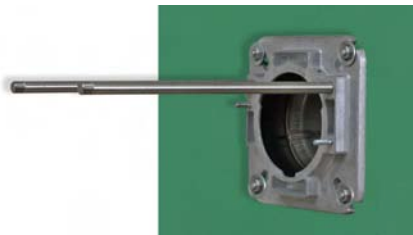

1. Separate the burner body and the flange.
2. Fit the flange and gasket on the boiler.
3. Insulate between the burner pipe and boiler door to reduce heat radiation.
4. Slide the burner body on to the guides.
5. Pull the brake plate off the oil pipe.
6. Fit the chosen nozzles (see Technical data).
7. Fit the brake plate and check the ignition electrodes (see Servicing the burner).
8. Slide the burner together and secure it with the nuts (E).

Oil lines



Return line Suction line

1. Check the size of the oil line (see Pump instructions).
2. An oil filter (1/2") must be fitted to the oil line. If an air trap is fitted then the oil filter should be fitted to the oil line before the air trap.
3. With a single pipe system the return plug must be removed (see Pump instructions).
4. When fitting oil hoses, check that the supply and return hoses are connected to the right couplings on the oil pump. The hoses must be positioned so that they are not subjected to tensile stress or sharp bending.
5. Bleed the oil system. The oil pump will be damaged if it is run dry.
6. The vacuum in the suction line should not exceed 0.3 bar during commissioning.

Electrical connections



1. Turn off the main power switch.
2. Connect the Eurostecker connectors (see Electrical equipment).
3. Check that the burner control switch (S1) is off.
4. Fit the Eurostecker connectors on the burner.
5. Turn on the main power switch.
6. Check the direction of rotation of the burner motor.

04. BASIC SETTINGS

Typical basic settings for B65-2H/B65-2/B65-2R/B65-3R

Choice of nozzle
B65-2H/B65-2/B65-2R

Burner output = 770 kW
Nozzle Stage 1 : $770 \times 0,6 = 460 \text{ kW}$ $460 / 11,86 = 38,8 \text{ kg/h}$
Nozzle Stage 2 : $770 \times 0,4 = 310 \text{ kW}$ $310 / 11,86 = 26,1 \text{ kg/h}$

According to the table of nozzles this gives the following nozzles:

Stage 1 : 8,50 Gph
Stage 2 : 6,00 Gph
Pump pressure : 14 bar

Basic settings
B65-2H

Nozzle assembly Stage 2 = 15
Air adjustment Stage 1 = 25°
Stage 2 = 65°

Each graduation on the scale corresponds to 10°.

Basic settings
B65-2

Power outputs and nozzle choice from example.

Nozzle assembly	Stage 2	=	15	
Damper motor	Closed	=	0°	Blue cam
	Stage 1	=	25°	Orange cam
	MV 2	=	50°	Black cam
	Stage 2	=	65°	Red cam

The black cam for Stage 2 (MV 2) must be placed between the cams for Stage 1 and Stage 2. The positions of MV 2 are determined by the boiler characteristics when switching between stages, but for a basic setting the black cam should be placed in the middle.

Basic settings
B65-2R

Power outputs and nozzle choice from example.

Nozzle assembly	Stage 1	=	0	
	Stage 2	=	15	
Damper motor	Closed	=	0°	Blue cam
	Stage 1	=	25°	Orange cam
	MV 2	=	50°	Black cam
	Stage 2	=	65°	Red cam

The black cam for Stage 2 (MV 2) must be placed between the cams for Stage 1 and Stage 2. The positions of MV 2 are determined by the boiler characteristics when switching between stages, but for a basic setting the black cam should be placed in the middle.

Choice of nozzle
B65-3R

Burner output = 880 kW
Nozzle $880 / 3 = 293 \text{ kW}$ $293 / 11,86 = 24,7 \text{ kg/h}$
According to the table of nozzles this gives the following nozzles:
Stage 1 : 5,50 Gph
Stage 2 : 5,50 Gph
Stage 3 : 5,50 Gph
Pump pressure : 14 bar

Basic settings
B65-3R

Power outputs and nozzle choice from example.

Nozzle assembly	Stage 1/2	=	5	
	Stage 3	=	20	
Damper motor	Stage 1	=	10°	Blue cam
	MV 2	=	30°	Black cam
	Stage 2	=	44°	Orange cam
	MV 3	=	60°	Green cam
	Stage 3	=	80°	Red cam

The cams for Stage 2 (MV 2) and Stage 3 (MV 3) must be placed between the cams for Stage 1 and Stage 2, and between Stage 2 and Stage 3, respectively. The positions of MV 2 and MV 3 are determined by the boiler characteristics when switching between stages, but for a basic setting the cams (MV2 and MV3) should be placed in the middle.

04. BASIC SETTINGS

Set values for nozzle assembly B55

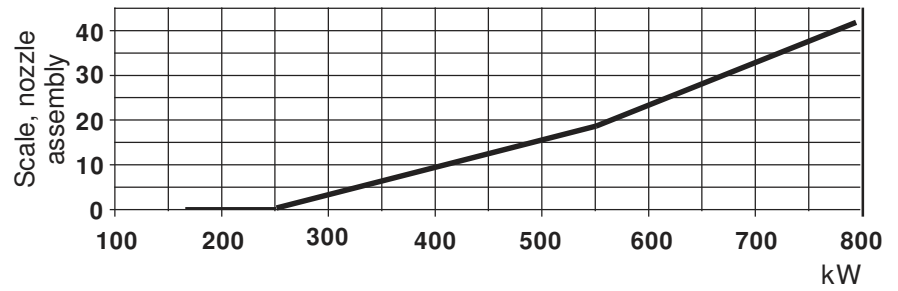

Set values for nozzle assembly B65

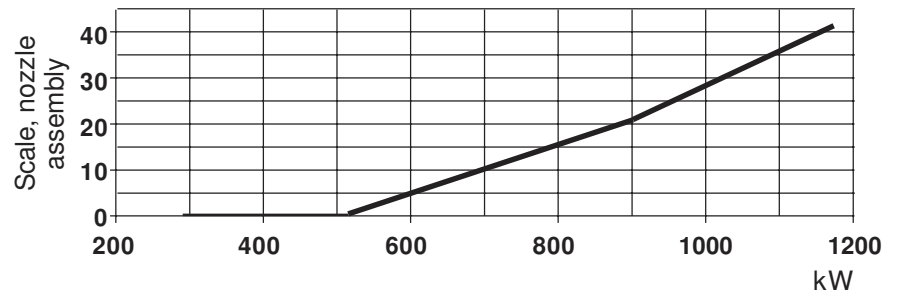

Set values for air damper B55

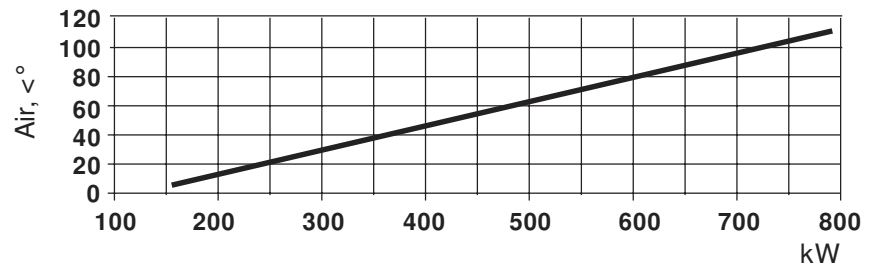

Set values for air damper B65

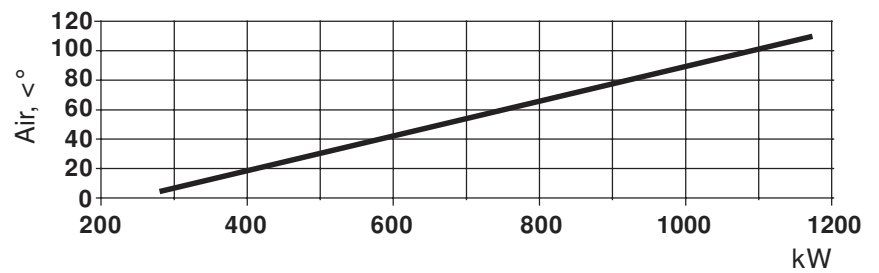

04. BASIC SETTINGS

Nozzle assembly regulation – fixed brake plate

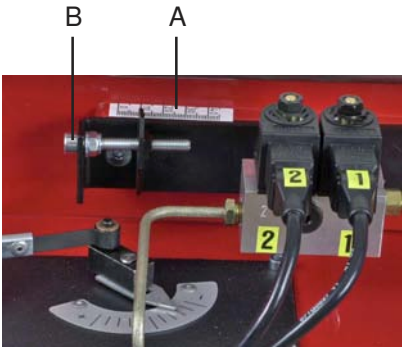

Nozzle assembly regulation is used to achieve the most favourable pressure drop possible across the brake plate.

Nozzle assembly regulation should be adjusted for Stage 2 output.

Adjustment

Adjust to the desired position on the scale (A) using the set screw (B) (turning anti-clockwise reduces the pressure drop and moves the brake plate outwards).

If pulsation occurs, the pressure drop across the brake plate can be altered until pulsation stops.

Nozzle assembly regulation – adjustable brake plate

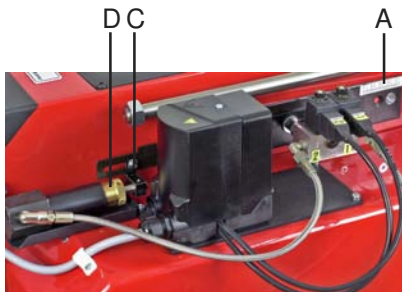

Nozzle assembly regulation is used to achieve the most favourable pressure drop possible across the brake plate for each output stage.

Two nozzles

Nozzle assembly regulation adjusts the position of the brake plate between Stage 1 and Stage 2 by means of a hydraulic piston.

Three nozzles

Nozzle assembly regulation adjusts the position of the brake plate between Stage 2 and Stage 3 by means of a hydraulic piston.

Low load

Undo the locking nut.

Adjust to the desired position on the scale (A) by sliding the plate to the desired position. Tighten the locking nut (C).

High load

Adjust to the desired position on the scale (A) using the set screw (D) (turning anti-clockwise reduces the pressure drop and moves the brake plate outwards).

If pulsation occurs, the pressure drop across the brake plate can be altered until pulsation stops.

Hydraulic air adjustment

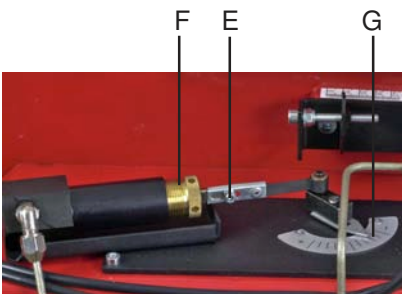

Stage 1

Set the control switch (S2) to low load (I). Undo the screw (E), turn the damper to the desired position and retighten the screw (E).

Stage 2

Set the control switch (S2) to high load (I). Use the adjuster pin to screw the sleeve (F) in (to reduce) or out (to increase). The position of the damper can be read from the damper scale (G). Carry out flue gas analysis to check the air settings.

04. BASIC SETTINGS

Damper motor 2-Stage

The damper motor rotates the damper between three preset positions. These positions are controlled at the motor by micro-switches, the switching positions of which are set using the coloured cams. There is also a black cam, which controls the activation of solenoid valve 2.

If the air flow requires adjustment:

Remove the cover from the damper motor and change the positions of the cams by turning them with the aid of the tool supplied. To deactivate a cam while you are turning it we recommend that you switch to a different stage and then switch back after adjustment is complete in order to check the result.

Stage 1

Adjust the operating switch to Stage 2 (II).

- * Reduce the air volume:
Turn orange cam towards 0°.
- * Increase the air volume:
Turn orange cam towards 90°.

Adjust the operating switch back to low capacity and check.

Stage 2

Adjust the operating switch to Stage 1 (I).

- * Reduce the air volume:
Turn red cam towards 0°.
- * Increase the air volume:
Turn red cam towards 90°.

If the red cam is moved, change the black cam as much. Adjust the operating switch back to Stage 2 and ensure that the correct air volume has been obtained.

Closed

The blue cam is the limit position for fully closed damper and it is normally not necessary to change it.

Releasing

The damper motor can be released using the white release button. This feature simplifies replacement of the damper motor.

To release. Press down the shaft and slide it outwards until it disengages from the milled slot.

To engage. Slide the shaft inwards and release. Adjust the position of the motor so that the cogs mesh with each other.

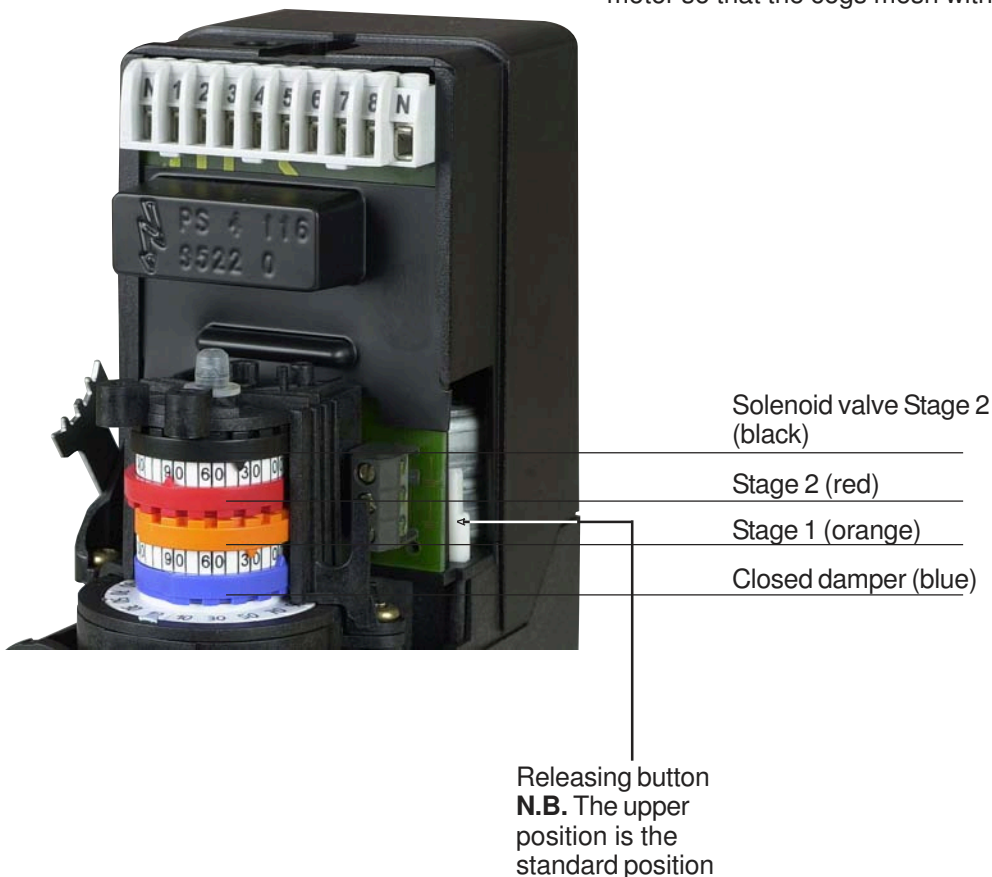

04. BASIC SETTINGS

Damper motor 3-Stage

The damper motor rotates the damper between three preset positions. These positions are controlled at the motor by micro-switches, the switching positions of which are set using the coloured cams. There is also a black cam, which controls the activation of solenoid valve 2 and a green one which controls the activation of solenoid valve 3.

If the air flow requires adjustment:

Remove the cover from the damper motor and change the positions of the cams by turning them with the aid of the tool supplied. To deactivate a cam while you are turning it we recommend that you switch to a different stage and then switch back after adjustment is complete in order to check the result.

Stage 1

Adjust the operating switch to Stage 2 (II).

- * Reduce the air volume:
Turn blue cam towards 0°.
- * Increase the air volume:
Turn blue cam towards 90°.

Adjust the operating switch back to Stage 1 and check.

Stage 2

Adjust the operating switch to Stage 1 (I).

- * Reduce the air volume:
Turn orange cam towards 0°.
- * Increase the air volume:
Turn orange cam towards 90°.

If the orange cam is moved, change the black cam as much. Adjust the operating switch back to Stage 2 and ensure that the correct air volume has been obtained.

Stage 3

Adjust the operating switch to Stage 2 (II).

- * Reduce the air volume:
Turn red cam towards 0°.
- * Increase the air volume:
Turn red cam towards 90°.

If the red cam is moved, change the green cam as much. Adjust the operating switch to Stage 3 (III) and ensure that the correct air volume has been obtained.

Releasing

The damper motor can be released using the white release button. This feature simplifies replacement of the damper motor.

To release. Press down the shaft and slide it outwards until it disengages from the milled slot.

To engage. Slide the shaft inwards and release. Adjust the position of the motor so that the cogs mesh with each other.

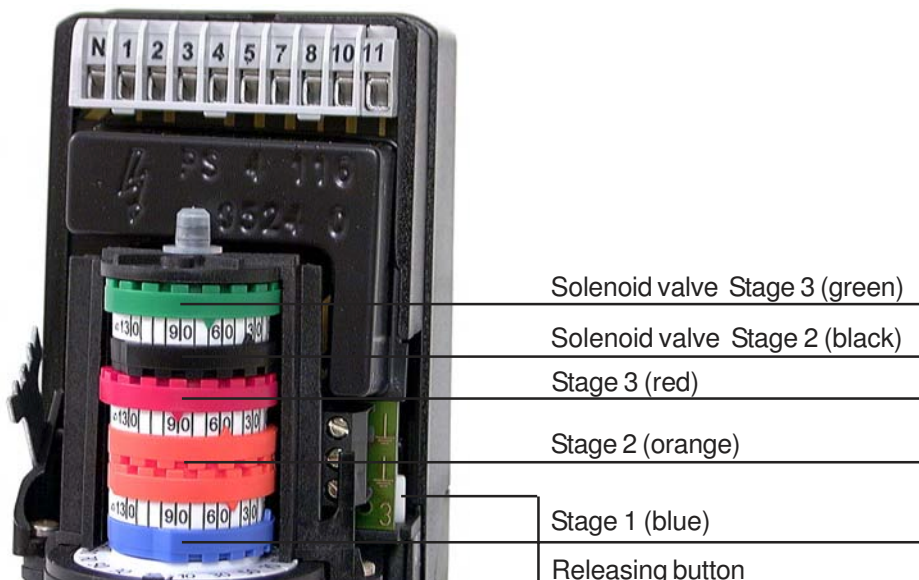

N.B. The upper position is the standard position

05. MAINTENANCE

Servicing the burner device

Removal and fitting

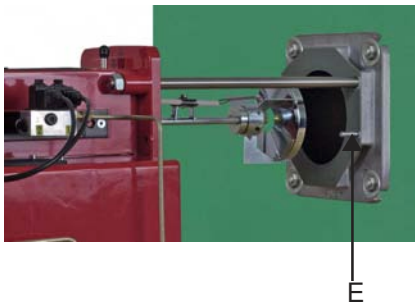

1. Turn off the main power switch and disconnect the Eurostecker connectors from the burner.
2. Undo the nuts (E) and pull out the burner body on its guides.
3. Undo and remove the brake plate from the oil pipe.
4. Unscrew the nozzles.
5. Fit the nozzles.
6. Fit the brake plate (see Adjusting the brake plate).
7. Check the ignition electrodes (see Adjusting ignition electrodes). Replace if necessary.
8. Slide the burner together and secure it with the nuts (E).
9. Connect the Eurostecker connectors and turn on the main power switch.
10. Check combustion*.

Note:

* After servicing/replacing components that affect combustion, a flue gas analysis and soot measurement must be carried out on the installation.

NOTE!

If nozzles are dirty always replace them with new ones. Do not clean them. On boilers with a hinged door, the door can be opened and the burner pipe can be removed from the flange and pulled forwards.

With burners that have an extended burner tube, the burner body must be lifted off the guides, or the oil pipe must be disconnected from the solenoid valves to be removed for servicing.

Adjusting the ignition electrodes and brake plate

Adjustment dimensions for ignition electrodes.



Burner, type	a	b	c	d	e
B55-2	2,5-3,0	2,0	6,5-7,0	2,0	6,0-7,0
B55-3	2,5-3,0	0,0	6,5-7,0	2,0	6,0-7,0
B65-2	2,5-3,0	2,0	6,5-7,0	2,0	10,0-12,0
B65-3	2,5-3,0	0,0	6,5-7,0	2,0	10,0-12,0

NOTE!

It is important that the spark does not strike the brake plate or nozzle.

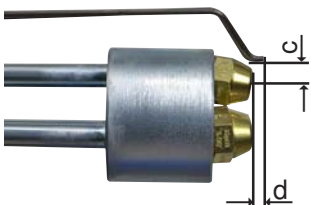
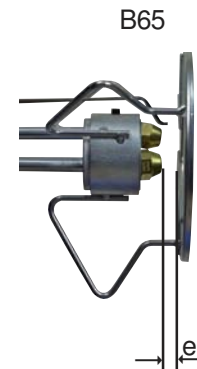
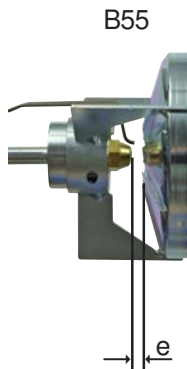

05. MAINTENANCE

Servicing the air damper

Removal and fitting

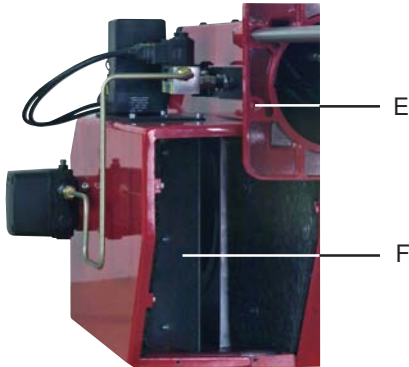

1. Turn off the main power switch and disconnect the Eurostecker connectors from the burner.
2. Undo the nuts (E) and pull out the burner body on its guides.
3. Remove the intake grille from the air intake.
4. Release the damper motor.
5. Clean the air damper (F) and the intake. Lubricate the damper shaft if applicable.
6. Re-engage the damper motor.
7. Fit the intake grille over the air intake.
8. Slide the burner together and secure it with the nuts (E).
9. Connect the Eurostecker connectors and turn on the main power switch.
10. Check combustion*.

Replacing the damper motor

Removal and fitting

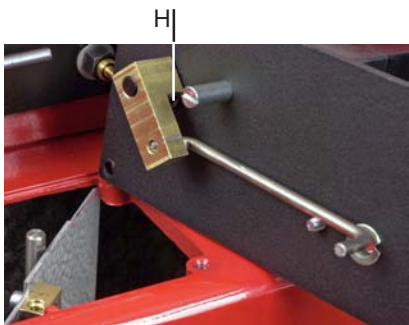
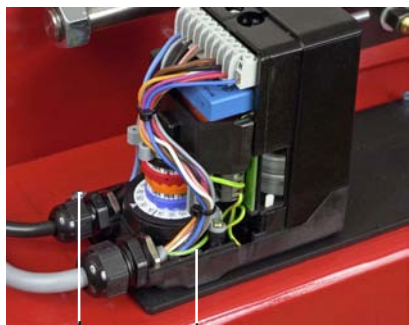

1. Turn off the main power switch and disconnect the Eurostecker connectors from the burner.
2. Note the positions of the cables and then disconnect the cables from the damper motor
3. Release the damper motor and lock it at 30°.
4. Fully open the insert.
5. Undo the screws (G) that secure the mounting plate for the damper motor.
6. Raise it carefully so that the air damper stays in the air intake.
7. Disconnect the (H) link arm from the motor shaft.
8. Separate the damper motor from the mounting plate (I).
9. Refit the damper motor on the mounting plate.
10. Connect the link arm to the damper motor shaft. It is important that the screw is at right angles to the plane of the shaft.
11. Release the damper motor and lock it at 30°.
12. Fit the mounting plate by guiding the link arm into the attachment point on the air damper and the air damper shaft into the mounting plate (make sure that the bushings are fitted between the mounting plate and damper shaft).
13. Release the damper motor and check that the damper moves freely. Close the damper and zero the graduated scale on the damper motor.
14. Make the electrical connections to the damper motor.
15. Reset the damper motor cams.
16. Connect the Eurostecker connectors and turn on the main power switch.
17. Check combustion.*

Replacing the oil pump B55/B65

Removal and fitting

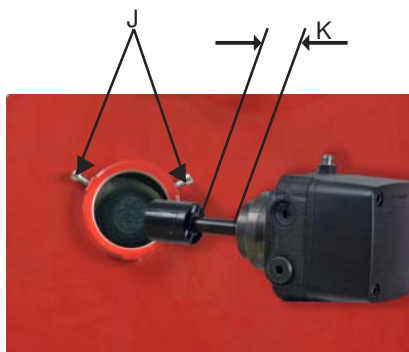

1. Turn off the main power switch and disconnect the Eurostecker connectors from the burner.
2. Disconnect the oil hoses from the pump.
3. Undo the screws (J) and pull out the oil pump.
4. Measure the distance between the pump mounting and the pump coupling (K).
5. Transfer the pump coupling to the new pump and adjust to give the same spacing between the pump and pump coupling as before (K)
6. Fit the oil pump on the burner and tighten the screws (J). (It is important that splines on the pump shaft align correctly with the pump coupling.)
7. Fit the oil hoses.
8. Connect the Eurostecker connectors and turn on the main power switch.
9. Bleed the pump, start the burner and adjust to the correct oil pressure.
10. Check combustion.*

Note:

- * After servicing/replacing components that affect combustion, a flue gas analysis and soot measurement must be carried out on the installation.

06. INSTRUCTIONS PUMP TYPE RSA 95 & 125

Technical data

	RSA 95	RSA 125
Viscosity range:	1,3-18,0 mm ² /s	
Pressure range at viscosity 1,3-1,8:	5,5-12,0 bar	
Pressure range at viscosity 1,8-18,0:	2,5-21,0 bar	
Oil temperature:	-10 to +70 °C	
Nozzle capacity at viscosity 4,3:	150-190 l/h	215-260 l/h
Gearwheel capacity:	225 l/h	294 l/h
Max pressure on suction- and return side:	4 bar	

Components

1. Pressure gauge port G 1/8"
2. Nozzle port G 1/4"
3. Suction line G 1/4"
4. Suction line G 1/4"
5. Return line G 1/4"
6. Return line G 1/4"
7. By-pass plug
8. Pressure adjustment, 4 mm Allen key



Mounting/dismounting by-pass plug

In a 2-pipe-system excess oil is led back direct to the oil tank. In a 1-pipe-system the by-pass plug must be removed so that there is a free passage back to the suction side through the return line with the return port closed. (Pos.7).

Purging

On 1-pipe systems it is necessary to purge the pump. On 2-pipe systems purging is automatic through the return line.

Replacing the filter

Replace the oil filter on the oil pump as follows.

- Close the oil valves.
- Unscrew the cover (4 x 5 mm Allen screws).
- Replace the oil filter.
- Replace the cover gasket.
- Refit the cover.
- Open the oil valves.



06. INSTRUCTIONS PUMP TYPE RSA 95 & 125

Function Danfoss RSA 95 - 125

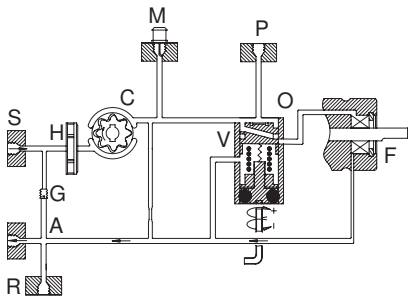

When the pump is started oil is drawn through the suction port "S" via filter "H" to the suction side of the gearwheel set "C". From here the gearwheel set pumps the oil to the pressure side and at the same time the oil becomes pressurized. The oil is led to cut-off and regulating valve "V" which opens when the set pressure is reached.

The pressure is controlled and kept constant by regulating valve "V". At the same time the gearwheel set "C" distributes the oil through nozzle port "P" and pump return side "R" via the shaft seal "F".

The quantity of oil supplied to nozzle port "P" is determined by the pressure set on regulating valve "V" and the nozzle/resistance in the nozzle line.

In 2-pipe-systems excess oil is led back to the oil tank. In 1-pipe-systems the by-pass plug "A" must be removed to give free flow back to the suction side via return line "G" with return port "R" closed.

When the pump is stopped, the pump output drops and produces a drop in the oil pressure. The spring in the regulating valve presses the regulating piston forward until it seals in port "P". This cuts off the oil flow to the nozzle and ensures that the nozzle line is effectively shut off.

If the pump is overloaded, i.e. more oil is demanded than the gearwheel is able to pump under the given conditions, the oil pressure falls below the set value because the piston of the regulating valve moves towards its closed position and partially or wholly cuts off the return oil via port "O".

This can be remedied by

- reducing the pump pressure
- reducing the capacity, i.e. smaller nozzle or greater resistance
- changing to a pump with higher capacity

Schematic diagram

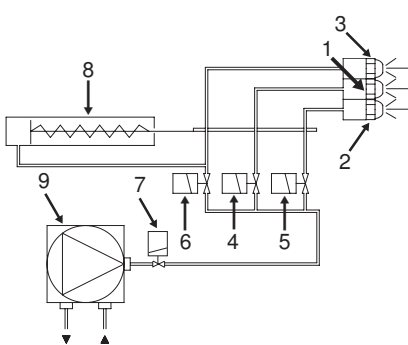

- | | |
|-----------------------------------------------------------------------------|--------------|
| 1. Nozzle | Stage 1 |
| 2. Nozzle | Stage 2 |
| 3. Nozzle | Stage 3 |
| 4. Solenoid valve | Stage 1 (Y1) |
| 5. Solenoid valve | Stage 2 (Y2) |
| 6. Solenoid valve | Stage 3 (Y3) |
| 7. Safety valve for nozzle (Y1S) | |
| Only for capacities over 100 kg/h or on special request by customer. | |
| 8. Hydraulic control device | |
| Only on burners with hydraulic air control or nozzle assembly optimisation. | |
| 9. Oil pump | |

Items 3 and 6 are not fitted to two-stage burners. Item 8 is connected after solenoid valve nozzle 2 (Y2).

06. INSTRUCTIONS PUMP TYPE RSA 95 & 125

Suction line tables

<p>1-pipe system</p> <table border="1"> <thead> <tr> <th>Height</th> <th colspan="3">Pipe diameter</th> </tr> <tr> <th>H</th> <th>ø12mm</th> <th>ø15mm</th> <th>ø20mm</th> </tr> <tr> <th>m</th> <th>m</th> <th>m</th> <th>m</th> </tr> </thead> <tbody> <tr> <td colspan="4">With an overlying tank a 1-pipe-system is not recommended.</td> </tr> </tbody> </table>	Height	Pipe diameter			H	ø12mm	ø15mm	ø20mm	m	m	m	m	With an overlying tank a 1-pipe-system is not recommended.				<p>1-pipe system</p> <table border="1"> <thead> <tr> <th>Height</th> <th colspan="3">Pipe diameter</th> </tr> <tr> <th>H</th> <th>ø12mm</th> <th>ø15mm</th> <th>ø20mm</th> </tr> <tr> <th>m</th> <th>m</th> <th>m</th> <th>m</th> </tr> </thead> <tbody> <tr> <td colspan="4">With an underlying tank a 1-pipe-system is not recommended</td> </tr> </tbody> </table>	Height	Pipe diameter			H	ø12mm	ø15mm	ø20mm	m	m	m	m	With an underlying tank a 1-pipe-system is not recommended																																																															
Height	Pipe diameter																																																																																												
H	ø12mm	ø15mm	ø20mm																																																																																										
m	m	m	m																																																																																										
With an overlying tank a 1-pipe-system is not recommended.																																																																																													
Height	Pipe diameter																																																																																												
H	ø12mm	ø15mm	ø20mm																																																																																										
m	m	m	m																																																																																										
With an underlying tank a 1-pipe-system is not recommended																																																																																													
<p>Two-pipe system</p> <table border="1"> <thead> <tr> <th>Height</th> <th colspan="3">Pipe diameter</th> </tr> <tr> <th>H</th> <th>ø12mm</th> <th>ø15mm</th> <th>ø20mm</th> </tr> <tr> <th>m</th> <th>m</th> <th>m</th> <th>m</th> </tr> </thead> <tbody> <tr><td>4,0</td><td>81</td><td>100</td><td>100</td></tr> <tr><td>3,5</td><td>76</td><td>100</td><td>100</td></tr> <tr><td>3,0</td><td>71</td><td>100</td><td>100</td></tr> <tr><td>2,5</td><td>66</td><td>100</td><td>100</td></tr> <tr><td>2,0</td><td>61</td><td>100</td><td>100</td></tr> <tr><td>1,5</td><td>56</td><td>100</td><td>100</td></tr> <tr><td>1,0</td><td>51</td><td>100</td><td>100</td></tr> <tr><td>0,5</td><td>46</td><td>100</td><td>100</td></tr> </tbody> </table>	Height	Pipe diameter			H	ø12mm	ø15mm	ø20mm	m	m	m	m	4,0	81	100	100	3,5	76	100	100	3,0	71	100	100	2,5	66	100	100	2,0	61	100	100	1,5	56	100	100	1,0	51	100	100	0,5	46	100	100	<p>Two-pipe system</p> <table border="1"> <thead> <tr> <th>Height</th> <th colspan="3">Pipe diameter</th> </tr> <tr> <th>H</th> <th>ø12mm</th> <th>ø15mm</th> <th>ø20mm</th> </tr> <tr> <th>m</th> <th>m</th> <th>m</th> <th>m</th> </tr> </thead> <tbody> <tr><td>0,0</td><td>41</td><td>100</td><td>100</td></tr> <tr><td>-0,5</td><td>36</td><td>89</td><td>100</td></tr> <tr><td>-1,0</td><td>31</td><td>77</td><td>100</td></tr> <tr><td>-1,5</td><td>26</td><td>65</td><td>100</td></tr> <tr><td>-2,0</td><td>22</td><td>53</td><td>100</td></tr> <tr><td>-2,5</td><td>17</td><td>41</td><td>100</td></tr> <tr><td>-3,0</td><td>12</td><td>29</td><td>91</td></tr> <tr><td>-3,5</td><td>7</td><td>17</td><td>53</td></tr> <tr><td>-4,0</td><td>2</td><td>5</td><td>15</td></tr> </tbody> </table>	Height	Pipe diameter			H	ø12mm	ø15mm	ø20mm	m	m	m	m	0,0	41	100	100	-0,5	36	89	100	-1,0	31	77	100	-1,5	26	65	100	-2,0	22	53	100	-2,5	17	41	100	-3,0	12	29	91	-3,5	7	17	53	-4,0	2	5	15
Height	Pipe diameter																																																																																												
H	ø12mm	ø15mm	ø20mm																																																																																										
m	m	m	m																																																																																										
4,0	81	100	100																																																																																										
3,5	76	100	100																																																																																										
3,0	71	100	100																																																																																										
2,5	66	100	100																																																																																										
2,0	61	100	100																																																																																										
1,5	56	100	100																																																																																										
1,0	51	100	100																																																																																										
0,5	46	100	100																																																																																										
Height	Pipe diameter																																																																																												
H	ø12mm	ø15mm	ø20mm																																																																																										
m	m	m	m																																																																																										
0,0	41	100	100																																																																																										
-0,5	36	89	100																																																																																										
-1,0	31	77	100																																																																																										
-1,5	26	65	100																																																																																										
-2,0	22	53	100																																																																																										
-2,5	17	41	100																																																																																										
-3,0	12	29	91																																																																																										
-3,5	7	17	53																																																																																										
-4,0	2	5	15																																																																																										

The suction line tables consist of theoretically calculated values where the pipe dimensions and oil velocity have been matched so that turbulences will not occur. Such turbulences will result in increased pressure losses and in acoustic noise in the pipe system.

In addition to drawn copper piping a pipe system usually comprises 4 elbows, a non-return valve, a cut-off valve and an external oil filter. The sum of these individual resistances is so insignificant that they can be disregarded.

The tables do not include any lengths exceeding 100 m as experience shows that longer lengths are not needed. The tables apply to a standard fuel oil of normal commercial quality according to current standards. On commissioning with an empty tube system the oil pump should not be run without oil for more than 5 min. (a condition is that the pump is being lubricated during operation).

The tables state the total suction line length in metres at a viscosity of 6,0 mm²/s.

09. ELECTRIC EQUIPMENT

Wiring diagram LOA44.../LMO24.255... (B55-2H/B65-2H)

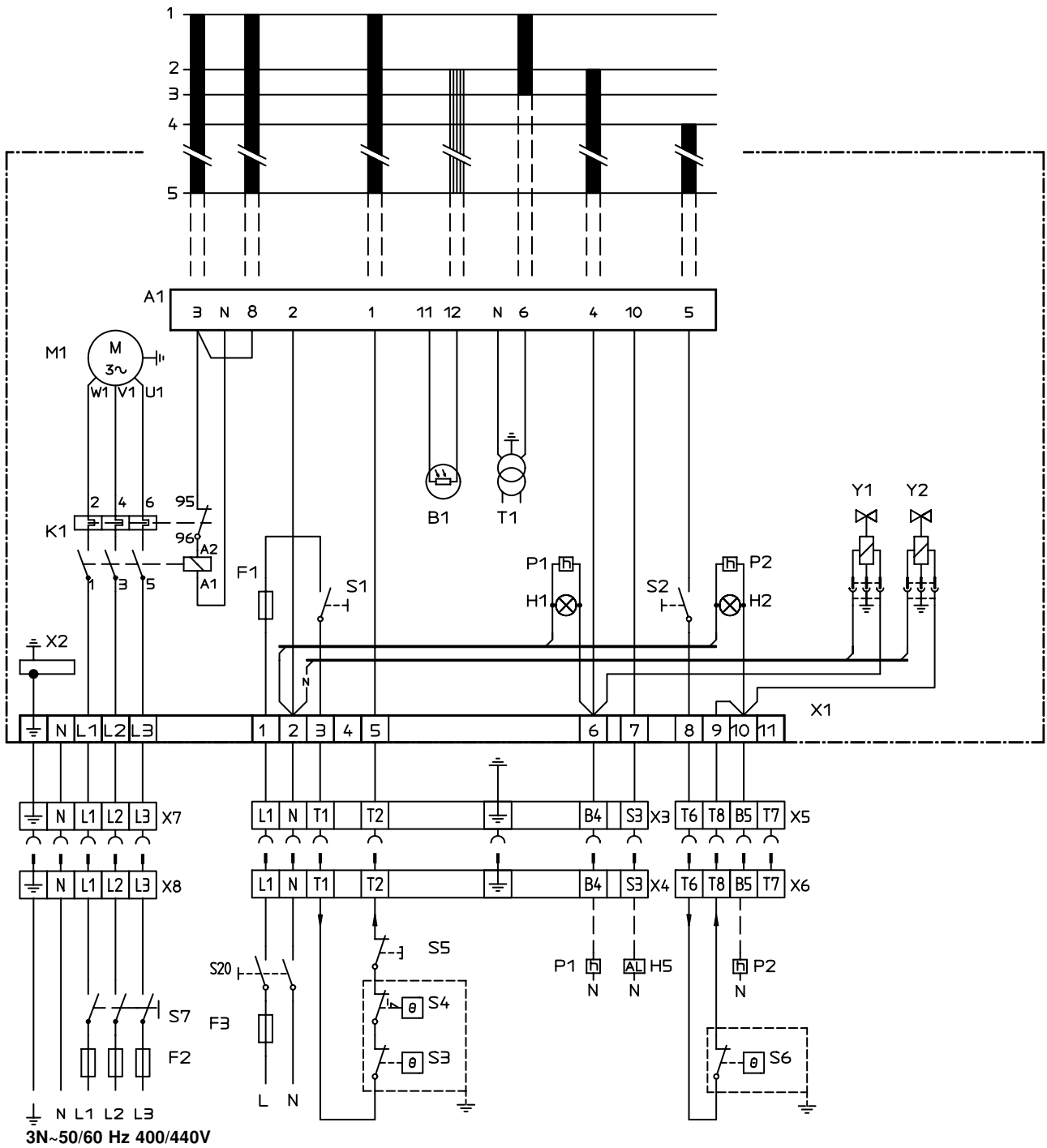

09. ELECTRIC EQUIPMENT

Wiring diagram LOA44.../LMO24.255... (B55-2/B65-2/B55-2R/B65-2R)

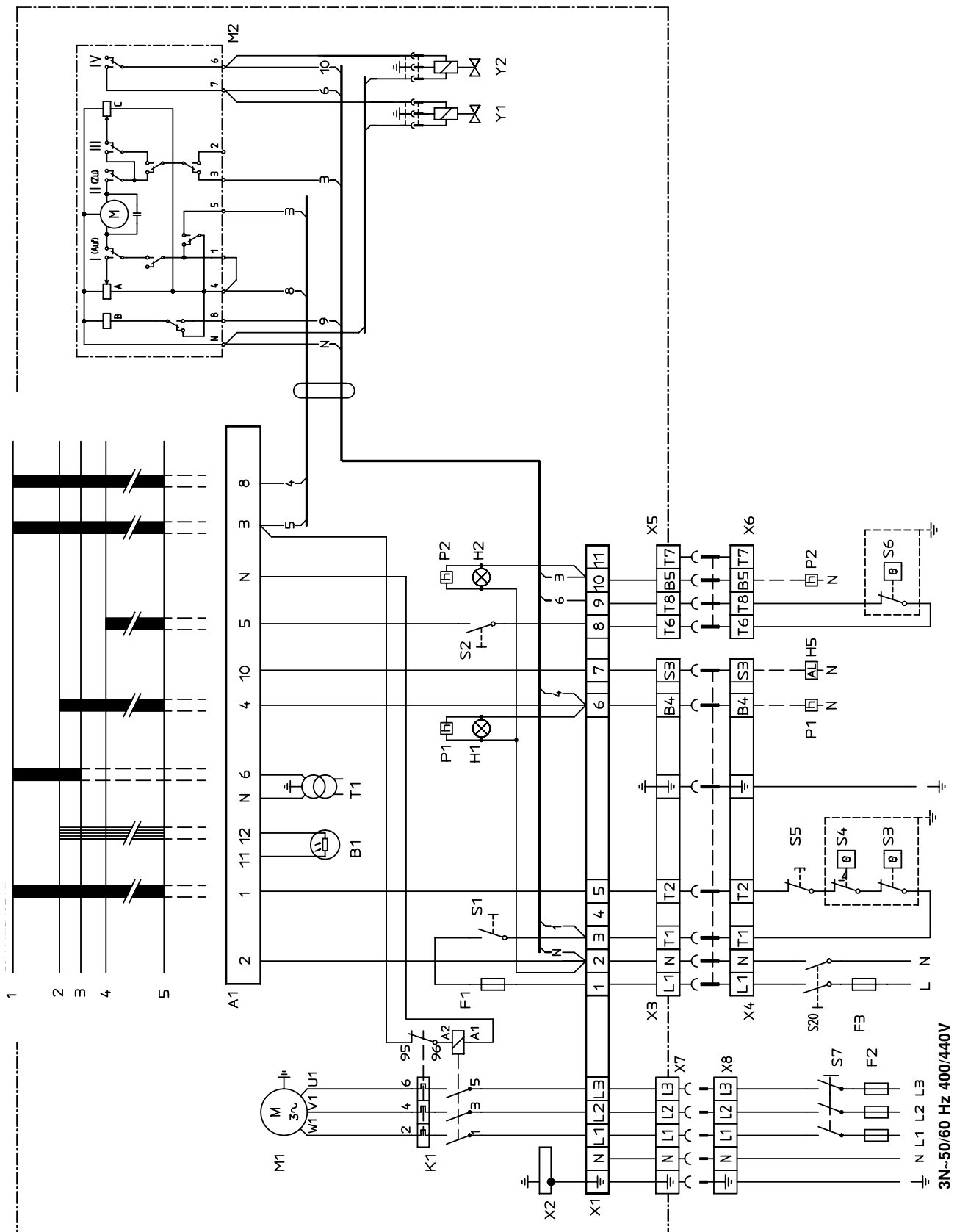

09. ELECTRIC EQUIPMENT

List of components LOA44.../LMO24.255... (B55-2H/B65-2H/B55-2R/B65-2R)

A1	Oil burner control	S6	Control thermostat, high/low
B1	Photoresistor	S7	Main switch 3-fas
F1	Operating fuse	S20	Main switch 1-fas
F2	Fuse	T1	Ignition transformer
F3	Fuse	X1	Connection terminal board
H1	Lamp, low capacity	X2	Earth terminal
H2	Lamp, high capacity	X3	Plug-in contact "Euro", burner
H5	Alarm signal 230V	X4	Plug-in contact "Euro", boiler
K1	Thermal overload protection	X5	Plug-in contact "Euro", high/low burner
M1	Burner motor	X6	Plug-in contact "Euro", high/low boiler
M2	Damper motor SQN75.244A21B	X7	Plug-in contact "Euro" 3-phase, burner
S1	Operating switch	X8	Plug-in contact "Euro", 3-phase, boiler
S2	Operating switch, high/low capacity	Y1	Solenoid valve 1
S3	Operation thermostat	Y2	Solenoid valve 2
S4	Temperature limiter		
S5	Micro switch for hinged door		

If S6 is missing connection between T6 and T8.

Mains connection and fuse in accordance with local regulations.

Function LOA44.../LMO24.255...

1. Switch on operating switch and twin thermostat

The burner motor starts, an ignition spark is formed, the prepurge goes on till the prepurge period expires and the solenoid valve 1 opens (2).

2. Solenoid valve 1 opens

Oil mist is formed and ignited. The photocell indicates a flame.

3. The safety time expires

- a. If no flame is established before this time limit the control cuts out.
- b. If for some reasons the flame disappears after this time limit, the burner will make an attempt to re-start.

4. Full load thermostat ON

The burner is in operating position and can now change between high and low capacity.

4-5. Operating position

If the burner operation is interrupted by means of the main switch or the thermostat, a new start takes place when the conditions in accordance with point 1 are fulfilled.

The oil burner control cuts out

A red lamp in the control is lit. Press the reset button and the burner re-starts.

Technical data LOA44.../LMO24.255...

	LOA44	LMO24
Pre-ignition time:	25 s	25 s
Pre-purge time	25 s	26 s
Post-ignition time:	2 s	5 s
Safety lock-out time:	< 5 s	< 5 s
Reset time after lockout:	2 s	< 1 s
Reaction time on flame failure:	< 1 s	< 1 s
Ambient temperature:	from - 20 to + 60°C	from - 5 to + 60°C
Min. current with flame established:	58 µA	45 µA
Max. photo current at start:	5,5 µA	5,5 µA
Enclosure:	IP 40	IP 40

Control of photo current

Current through photo unit is measured with a d.c. ammeter (a moving coil instrument connected in series with the photo unit).

09. ELECTRIC EQUIPMENT

Wiring diagram LAL 1... (B55-2/B55-2R/B65-2/B65-2R)

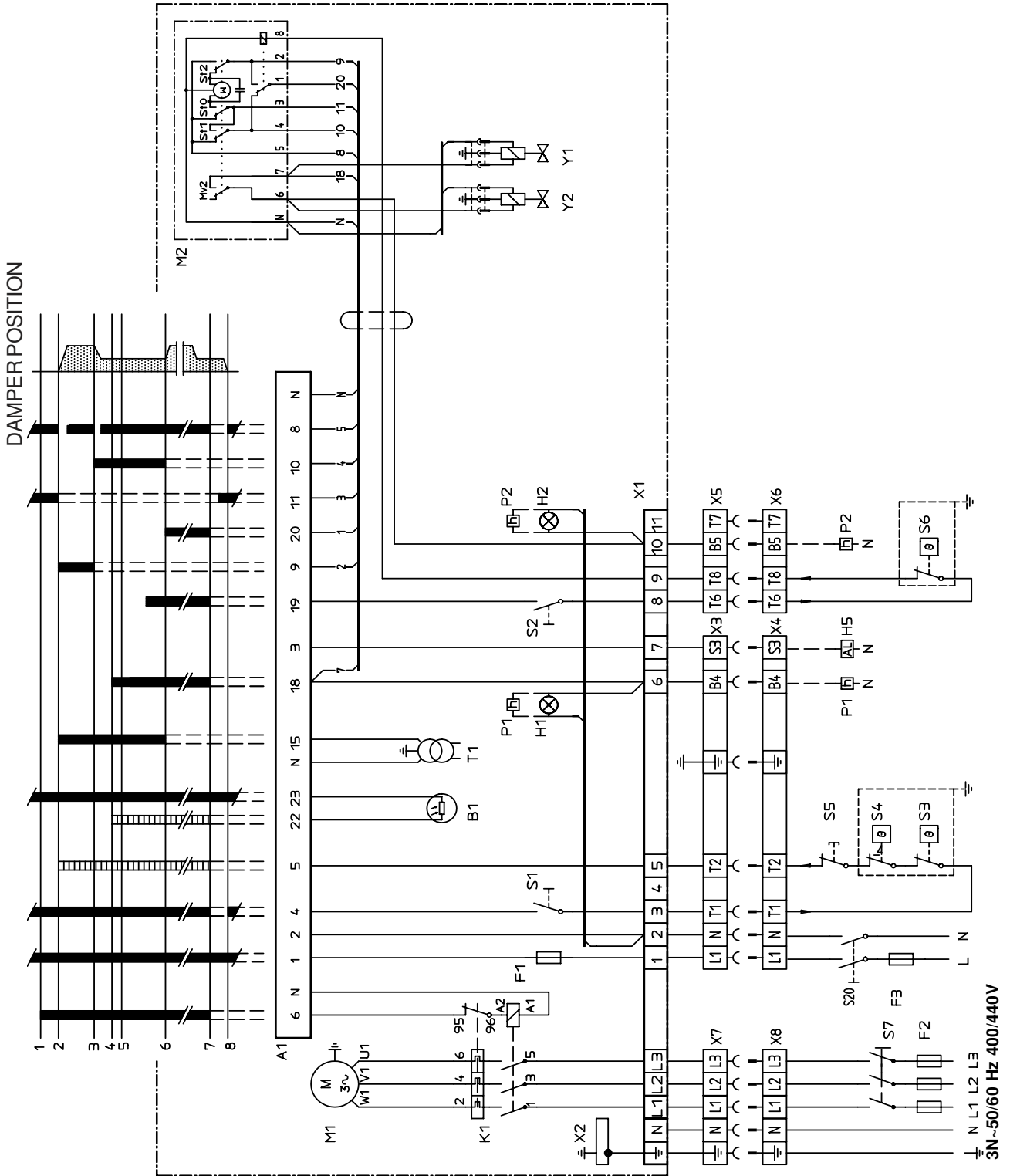

09. ELECTRIC EQUIPMENT

List of components LAL 1... (B55-2/B55-2R/B65-2/B65-2R)

A1	Oil burner control	S5	Micro switch for hinged door
B1	Photoresistor	S6	Control thermostat, high/low capacity
F1	Operating fuse	S7	Main switch 3-fas
F2	Fuse	S20	Main switch 1-fas
F3	Fuse	T1	Ignition transformer
H1	Lamp, low capacity	X1	Connection terminal board
H2	Lamp, high capacity	X2	Earth terminal
H5	Alarm signal 230V	X3	Plug-in contact "Euro", burner
K1	Thermal overload protection	X4	Plug-in contact "Euro", boiler
M1	Burner motor	X5	Plug-in contact "Euro", high/low burner
M2	Damper motor L&S SQN75.294A21B	X6	Plug-in contact "Euro", high/low boiler
P1	Time meter, low capacity (optional)	X7	Plug-in contact "Euro", 3-phase, burner
P2	Time meter, high capacity (optional)	X8	Plug-in contact "Euro" 3-phase, boiler
S1	Operating switch	Y1	Solenoid valve 1 "
S2	Operating switch, high/low capacity	Y2	Solenoid valve 2
S3	Operation thermostat		
S4	Temperature limiter		

If S6 is missing connection between T6 and T8.

Mains connection and fuse in accordance with local regulations.

Function LAL 1...

1. Operating switch ON, twin thermostat ON Air damper closed

The burner motor starts.

2. Ignition spark is formed

Ignition spark is formed. Air damper motor opens the damper to full load position.

3. Air damper motor closes

The air damper motor closes to low load position.

4. Solenoid valve opens

The oil mist is ignited. The photoresistor indicates a flame.

5. The safety time expires

- If there is no flame established **before** this time limit the burner control locks out.
- If the flame for some reason disappears **after** this time limit the burner control also locks out. If a repetition of the start-up sequence is desired, the wire link marked "Repetition" on the side of the base plate of the control must be removed.

6. Full load thermostat ON

The burner is in operating position. It can now change over to full load and then it alternates between full load and low load.

7. Stop

The burner operation is interrupted by means of the operating switch or if the thermostat switches off. The air damper closes completely and the oil burner control continues to position 8 for a new start.

8. State of rest

The burner is waiting for a new start.

The control locks out

A red lamp in the control is lit. Move the transparent cover aside and restart the burner by pressing the reset button.

Note!

In the window of the control symbols appear showing in which position the control locks out, see the adjoining explanation.

09. ELECTRIC EQUIPMENT

Wiring diagram LAL 1... (B55-3/B65-3 with regulator RT 16)

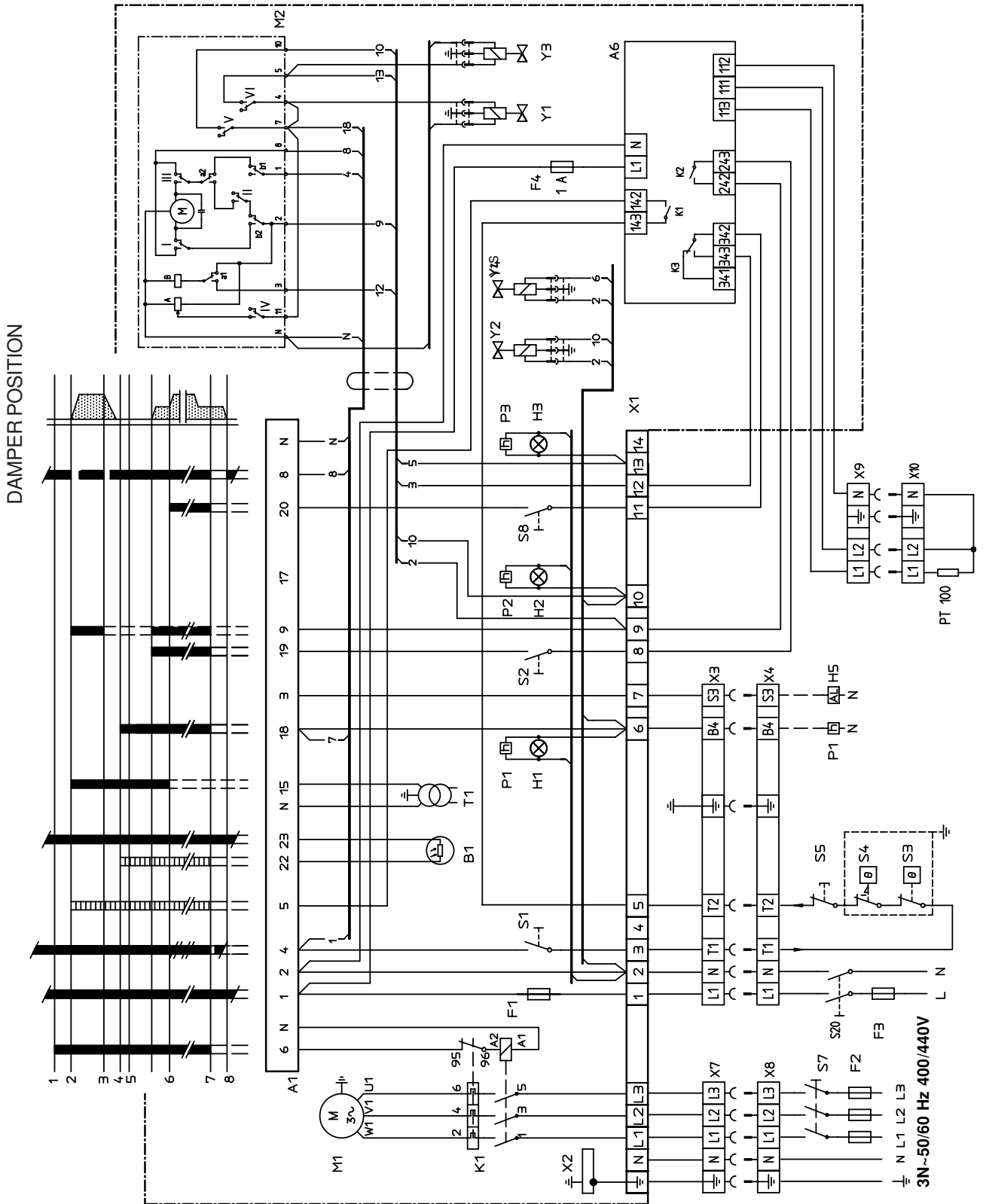

09. ELECTRIC EQUIPMENT

List of components LAL 1... (B55-3/B65-3 och B55-3/B65-3)

A1	Oil burner control	S20	Main switch 1-phase
A6	Regulator RT 16	T1	Ignition transformer
B1	Photoresistor	X1	Connection terminal board
F1	Operating fuse	X2	Earth terminal
F2	Fuse	X3	Plug-in contact "Euro", burner
F3	Fuse	X4	Plug-in contact "Euro", boiler
F4	Fuse 1A	X5	Plug-in contact "Euro", Stage 3 burner
H1	Lamp, Stage 1	X6	Plug-in contact "Euro", Stage 3 boiler
H2	Lamp, Stage 2	X7	Plug-in contact "Euro" 3-phase, burner
H3	Lamp, Stage 3	X8	Plug-in contact "Euro", 3-phase, boiler
H5	Alarm signal 230V	X9	Plug-in contact regulator, burner
K1	Thermal overload protection	X10	Plug-in contact regulator, PT 100-resistance thermometer
M1	Burner motor	X23	Plug-in contact "Euro", Stage 2 burner
M2	Damper motor L&S SQN75.436A21B	X24	Plug-in contact "Euro", Stage 2 boiler
P1	Time meter, Stage 1	Y1	Solenoid valve 1
P2	Time meter, Stage 2	Y2	Solenoid valve 2
P3	Time meter, Stage 3	Y3	Solenoid valve 3
S1	Operating switch	Y1S	Safety solenoid valve (Only burners with a capacity over 100 kg/h)
S2	Operating switch, Stage 2		
S3	Operation thermostat		
S4	Temperature limiter		
S5	Micro switch for hinged door		
S6	Control thermostat, Stage 2		
S7	Main switch 3-phase		
S8	Operating switch, Stage 3		
S9	Control thermostat, Stage 3		

If S6 is missing connection between L1 and L2.

If S9 is missing connection between T6 and T8.

Mains connection and fuse in accordance with local regulations.

Function LAL 1...

1. Operating switch ON, twin thermostat ON Air damper closed

The burner motor starts.

2. Ignition spark is formed

Ignition spark is formed. Air damper motor opens the damper to stage 3.

3. Air damper motor closes

The air damper motor closes to stage 1.

4. Solenoid valve 1 opens

The oil mist is ignited. The photoresistor indicates a flame.

5. The safety time expires

- If there is no flame established **before** this time limit the burner control locks out.
- If the flame for some reason disappears **after** this time limit the burner control also locks out. If a repetition of the start-up sequence is desired, the wire link marked "Repetition" on the side of the base plate of the control must be removed.

6. Thermostat and switch Stage 2 ON

The burner can now change over to stage 2.

7. Thermostat and switch Stage 3 ON

The burner can now change over to stage 3.

8-9. Operating position

The burner can now change between stage 1, 2 and 3. The burner operation is interrupted by means of the operating switch or the thermostat.

The control locks out

A red lamp in the control is lit. Move the transparent cover aside and restart the burner by pressing the reset button.

Note!

In the window of the control symbols appear showing in which position the control locks out, see the adjoining explanation.

09. ELECTRIC EQUIPMENT

Control programme under fault conditions and lock-out indication LAL 1...

In the event of fault conditions the sequence switch stops and simultaneously the lock-out indicator. The symbol appearing above the reading mark indicates kind of fault:

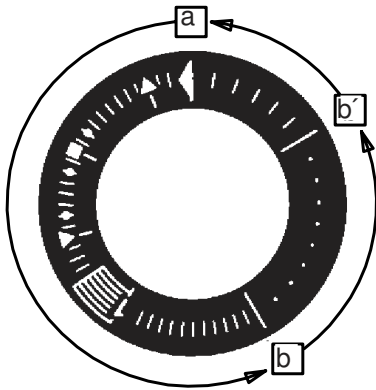

- ◀ **No start,**
because e.g., the CLOSE signal has not been supplied to terminal 8 by the limit switch, or a contact has not been closed between terminals 4 and 5.
- ▲ **Shut-down of start-up sequence,**
because the OPEN signal has not been supplied to terminal 8 by the limit switch. Terminals 6, 7 and 15 remain under voltage until the fault is corrected.
- **Lock-out**
due to a fault in the super-vision circuit.
- ▼ **Shut-down of start-up sequence,**
because the position signal for the low-flame position has not been supplied to terminal 8 by the auxiliary switch. Terminals 6, 7 and 15 remain under voltage until the fault is corrected.
- 1 **Lock-out,**
because no flame signal has been received on completion of the safety time.
- | **Lock-out,**
because the flame signal has been lost during burner operation or air pressure failure has occurred.
- ◀ **Lock-out on completion or after completion of control programme sequence**
due to extraneous light (e.g. flame not extinguished, leaking fuel valves) or due to a faulty flame signal (e.g. fault in flame supervision circuit or similar).

a - b Start-up sequence

b - b' "idle steps"
up to the self shutdown of the sequence switch

b (b') - a Post-purge sequence

Technical data LAL 1...

Pre-ignition time:	from start
Pre-purge time with full air volume:	22 s
Safety time:	5 s
Post-ignition time:	15 s
Interval between Mv1 and Mv2:	7,5 s
Reset after lock-out:	Immediately
Time of re-start:	47 s
Ambient temperature:	- 20 to + 60 °C
Min. required current at 220 V and 240 V respectively:	95/105 µ A
Max. current:	160 µ A
Protective standard:	IP40

Control of photo current

Current through photo unit is measured with a d.c. ammeter (a moving coil instrument connected in series with the photo unit).

09. Manual for RT 16

Type designation: 703011/10-001-000-101-23/000

Manual RT 16

Change to the next level with the PGM button (press for 2 secs.)

- * Go on to the next parameter with PGM
- * Go back to normal showing with EXIT (goes back automatically after 30 secs. if no change has been done)
- * Change the value by ▲ or ▼. The value increases if the button is pressed down. The new value will be stored after 2 secs (the display flashes)

Normal showing

The display shows the present value and the setpoint. The setpoint is to be changed with ▲ or ▼.

Parameter level

The PGM-button should be pressed for 2 secs. to come down to this level, where the value for the limit alarm and the parameters of the regulator should be programmed.

Configuration level

At position y.0 in the parameter level the PGM-button should be pressed for 2 secs. to come down to this level. At this level the basic setting of the regulator should be made.

When setting the configuration codes, the following applies:

- Choose the digit with ▼ (actual digit flashes)
- Change the digit with ▲
- Confirm the code with PGM (regret with EXIT)

Parameter level

Parameter	Value	Remark
AL1	6	Limit alarm relatively W
AL2	10	Limit alarm relatively W
Pb1	0	
dt	0	
rt	0	
Cy1	0.5	
Hys1	3	
y.0	0	(PGM 2 secs. next level)
y 1	100	
y 2	0	
dF	0.6	
rASd	0	
SP1	40	Setpoint 1
SP2	0	Setpoint 2

Configuration level

Parameter	Value	Remark
C111	0000	
C112	4400	
C113	0013	
C114	0104	
SCL	0	
SCH	100	
SPL	0	Min setpoint
SPH	100	Max setpoint
OFFS	0	
Hyst	4	Hysteresis AL1 AL2

PGM
>2 secs

For a more detailed description please see the manual accompanying the regulator.

09. Manual for RT 16

Function RT 16

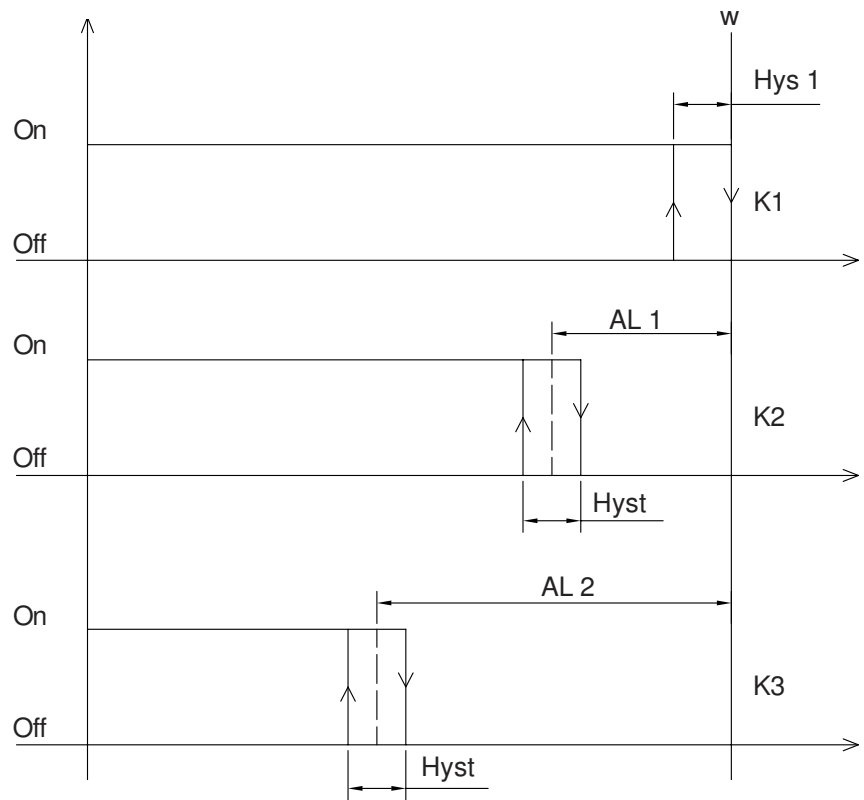

- W = Setpoint
- K1 = Relay outlet 1 (Stage 1)
- K2 = Relay outlet 2 (Stage 2)
- K3 = Relay outlet 3 (Stage 3)
- Hys1 = Switch on/off hysteresis (Stage 1)
- Hyst = Switch on/off hysteresis (Stage 2, Stage 3)

Example of the RT 16 operation mode

- W = 80° C
- AL1 = 6° C
- AL2 = 10° C
- Hys1 = 3° C
- Hyst = 4° C

Stage 1

- Start = $W - \text{Hys1}$ ($80 - 3 = 77$)
- Stop = W (80)

Stage 2

- Start = $W - \text{AL1} - \text{Hyst}/2$ ($80 - 6 - 4/2 = 72$)
- Stop = $W - \text{AL1} + \text{Hyst}/2$ ($80 - 6 + 4/2 = 76$)

Stage 3

- Start = $W - \text{AL2} - \text{Hyst}/2$ ($80 - 10 - 4/2 = 68$)
- Stop = $W - \text{AL2} + \text{Hyst}/2$ ($80 - 10 + 4/2 = 72$)

10. FAULT LOCATION

Burner fails to start

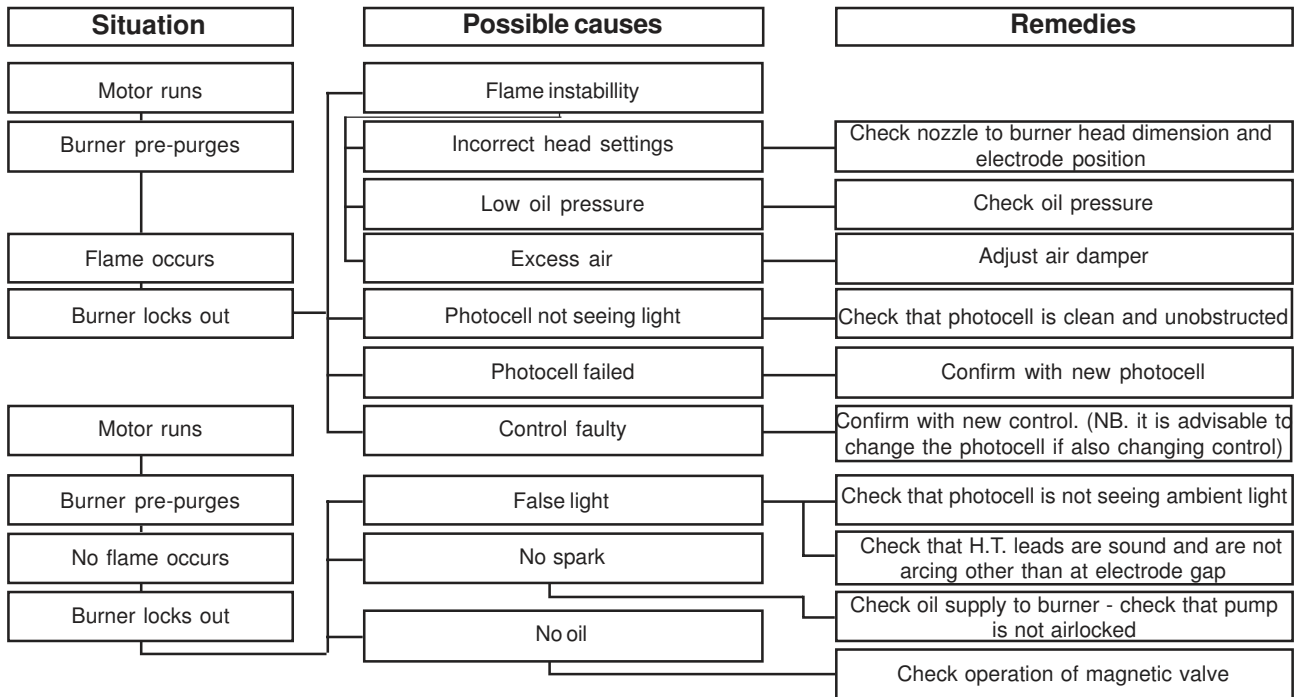

Burner fails to start after normal operation

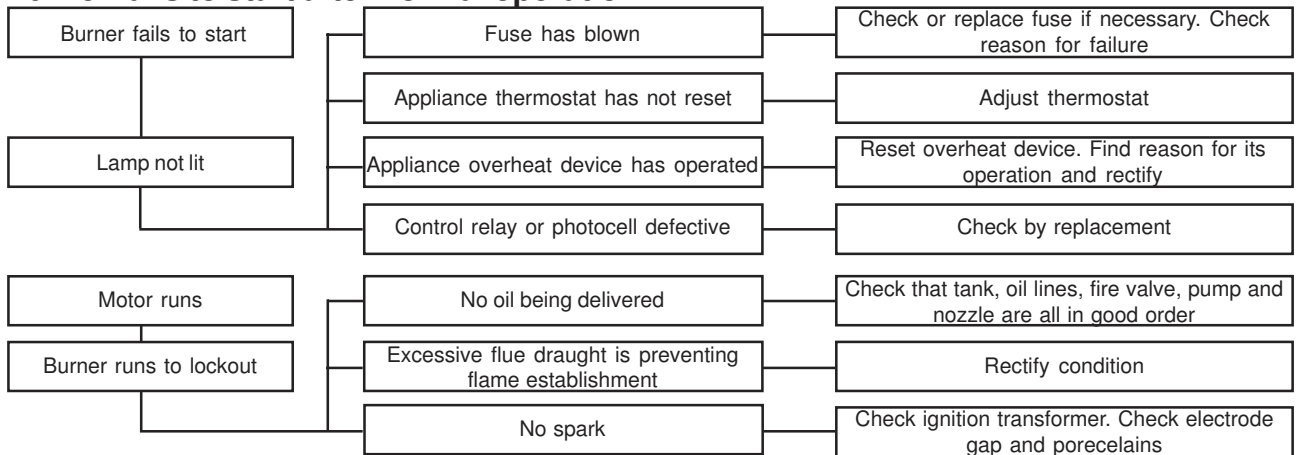

Delayed ignition, burners starts violently

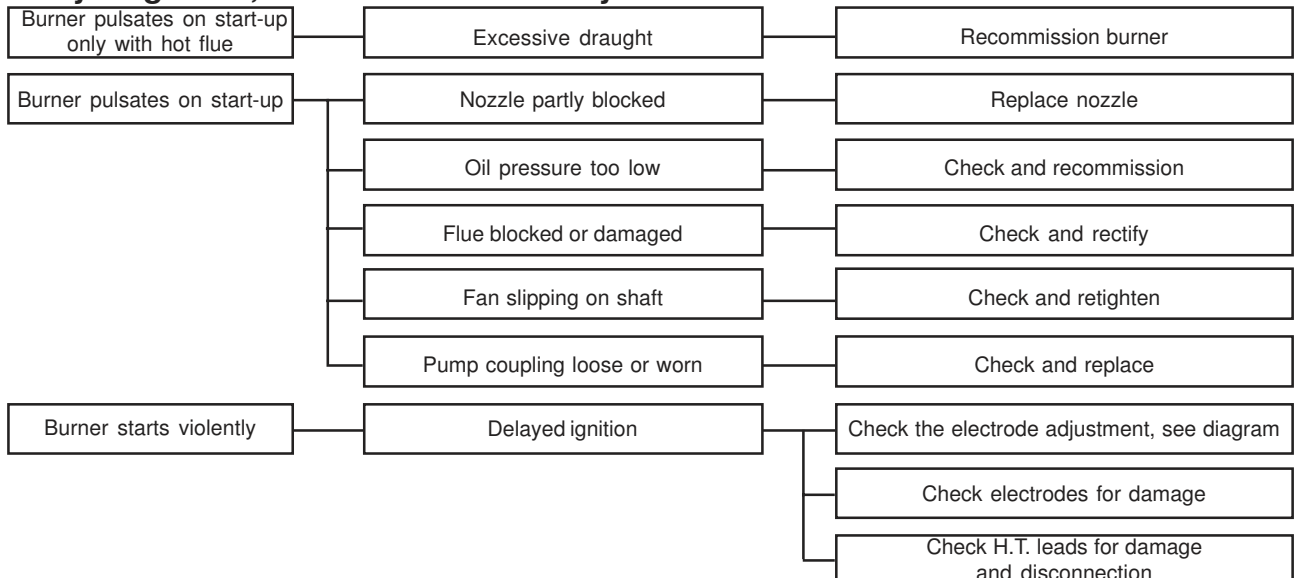

11. SPARE PART LIST



11. SPARE PART LIST

1. Flame cone		10. Axle compl.		27. Pump	
304mm	119 728 0105	55-2, 65-2	918 298 02	RSA95	110 197 23
404mm	119 728 0205	55-3, 65-3	918 298 01	55	
504mm	119 728 0305			RSA125	110 197 19
55		11. Adjustment bar		65	
288mm	119 721 0105	55-3, 65-3	118 450 01		
388mm	119 721 0205	55-2, 65-2	118 290 01	28. Solenoid valve	919 946 01
488mm	119 721 0305			compl.	
65		12. Adjustment device		Coil	115 971 01
		55-R, 65-R	918 299 04	29. Solenoid valve	919 947 01
2. Nozzle assembly		13. Gasket set		bloc compl.	
380mm	919 746 01	55-R, 65-R	118 322 02	55-2, 65-2	
480mm	919 746 02			30. Solenoid valve	919 947 02
580mm	919 746 03	14. Nozzle key	113 461 01	bloc compl.	
55-2				55-3, 65-3	
380mm	919 749 01	15. O-ring, nozzle assembly		31. Connecting pipe	118 237 01
480mm	919 749 02	55-3, 65-3	113 168 02	pump-solenoid valve bloc	
580mm	919 749 03			compl.	
65-2		16. Fixing flange	118 490 02	55-2H, 65-2H	
368mm	919 750 01	compl.		32. Connecting pipe	118 428 01
468mm	919 750 02	Guide bars	118 093 02	solenoid valve-	
568mm	919 750 03	Fixing flange	118 235 01	adjustment device	
55-3				55-2H, 65-2H	
368mm	919 751 01	17. Gasket	112 788 03	33. Nipple, connection	118 423 01
468mm	919 751 02			solenoid valve bloc	
568mm	919 751 03	18. Gasket	118 398 01		
65-3		fan housing-flange		34. Angle	118 404 01
				55-2, 65-2	
3. Nozzle line		19. Motor		35. Copper gasket	110 212 16
368mm	118 414 01	0,75kW 3-phase	120 316 01	10,2x15x1,5	
468mm	118 414 02	55		36. Cable solenoid valve	
568mm	118 414 04	1,5kW 3-phase	120 316 03	Stage1, 3 700mm	115 975 03
55-3, 65-3		65		Stage2 900mm	115 975 06
380mm	118 104 01	20. Cable 700mm	119 449 03	37. Hydraulic hose	118 293 01
480mm	118 104 02			55-2, 65-2	
580mm	118 104 04	21. Fan wheel		38. Hydraulic hose	116 168 01
55-2, 65-2		224x62x19	118 245 04	65-2	
		55		39. Filter set	117 833 01
4. Brake plate		224x82x19	118 245 05	RSA 90, 125	
55-2, Ø120mm	119 347 01	65		40. Control box	
55-3, Ø120mm	119 735 01	22. Drive coupling	118 115 03	LAL 1.25	914 939 01
65-2, Ø120mm	112 841 15	compl.		LOA44252A27	915 595 02
65-3, Ø120mm	112 841 19			LMO24.255.R2B	920 242 01
		23. Coupling part,	04 390 448 66	55-2, 65-2	
5. Bracket	112 738 01	pump			
6. Bracket	111 552 01	24. Coupling part,	118 065 01		
		fan wheel			
7. Ignition electrode pair off		25. Flange,	119 737 0105		
55-3, 65-3	919 247 01	motor			
65-2	919 246 01	26. Conical shield	117 935 01		
55-2	919 245 01	plate			
8. Adjustment plate compl.					
55-2H, 65-2H	118 229 01				
9. Adjustment plate compl.					
55-R, 65-R	918 288 01				

11. SPARE PART LIST

41. Relay base		53. Inspection glass	118 088 01
LAL	114 942 00		
LOA/LMO	915 596 00	54. Gasket	117 953 01
55-2, 65-2			
42. Flange,	112 405 01	55. Protective grating	118 319 01
Photoresistor			
QRB1		56. Cover	118 238 0105
43. Photoresistor	912 409 08	57. Gasket	118 249 01
compl.			
QRB-A		58. Cover,	118 242 0105
700mm		inspection glass	
44. Contactor CI 9	113 110 01	59. Inspection cover	117 080 01
45. Thermal overload		60. Test nipple	118 053 01
protection			
2,7-4,2A	113 111 03	61. Slewing bracket	119 470 01
65		compl.	
1,8-2,8A	113 111 06	62. Covering plate,	
55		servo motor	118 239 0105
46. Switch		adjustment	118 401 0105
HI	120 149 01	device	
0-I	120 149 02	55-2H, 65-2H	
47. Time meter	117 678 01	63. End piece	118 103 01
48. Plug-in contact compl.		64. Servo motor	
female 7-pole	115 586 03	SQN75.294A21B	119 423 03
male 7-pole	115 585 00	2-stage, LAL	
green		SQN75.436A21B	119 423 01
male 4-pole	119 197 01	3-stage, LAL	
female 4-pole	119 198 01	SQN75.244A21B	119 423 04
55-2, 65-2 stage 2		2-stage, LOA/LMO	
55-3, 65-3 stage 3		65. Air damper	918 240 01
black		compl.	
male 4-pole	119 103 01	55-2H, 65-2H	918 241 01
female 4-pole	119 104 01	66. Adjustment device	917 565 03
55-3, 65-3 stage 2		55-2H, 65-2H	
male 5-pole	119 199 01	Spring, compl.	133 799 01
female 5-pole	119 200 01	adjustment device	
49. Indicating lamp	117 211 03	55-2H, 65-2H	
green		67. Transformer EBI	115 977 01
50. Fuse holder compl.		Cabel	117 570 04
55-3, 65-3	118 118 03	68. Ignition cable	119 337 06
55-2, 65-2	118 118 04	500mm	
Fuse 6,3A	113 322 01	69. Flexible pipe	113 542 08
51. Plug-in contact compl.		1500mm	
7+4+5+4-pole	119 486 10	70. Oil filter compl. 1/2"	114 293 04
55-3, 65-3		Filter	914 314 03
4+7+5-pole	119 486 01		
55-2, 65-2			
52. Locking ring	118 018 01		

Enertech Limited,
P O Box 1,
Vines Lane
Droitwich,
Worcestershire,
WR9 8NA

Tel: +44 (0) 1905 794331
Email: info@nu-way.co.uk

Fax: +44 (0) 1905 794017
Web: www.nu-way.co.uk

